



*Grand 500*

*Grand 120*

Digital Grand Piano

Owner's Manual



<b>TABLE OF CONTENTS</b>		<b>1</b>	
Safety Precautions And Instructions	3	Single Finger Mode	25
Disclaimer	4	Registration Memory	26
Taking Care Of Your Instrument	4	How To Store The Registration Memories	26
Getting Started	5	How To Select A Memory Bank	26
Preparation	5	How To Select A Memory Registration	26
Power Supply	5	The Lock Button	27
Headphones	5	USB Disk	27
Bluetooth Audio Connection	6	Play Midi Files	27
Playing Demo Songs	6	Recording Station	28
Soft/Sostenuto/Sustain Pedals	7	Easy Recording	28
Programable Sustain Pedal (Half Sustain)	7	Multi Track Recording	29
Programable Sustain Sedal (Expression Pedal)	8	Function Button	31
Volume & Tone Controls	9	Main Voice Reverb Level	31
Selecting And Playing The Voices (Sounds)	9	Layer Voice Reverb Level	31
Sound Select	10	Left Voice Reverb Level	32
Main Voice	10	Main Voice Chorus Level	32
Layer Voice	10	Layer Voice Chorus Level	32
Left Voice	11	Left Voice Chorus Level	33
Sound Volume	12	Chord Type	33
Grand Piano Button	12	Metronome Volume	33
Favorite Voice Group	13	Main Voice Pan	34
Changing Your Favorite Voice Group	13	Layer Voice Pan	34
Select The Split Point	14	Left Voice Pan	34
Digital Reverb	14	Main Voice Octave	35
Chorus Effect	15	Layer Voice Octave	35
Touch Sensitivity	15	Left Voice Octave	35
Transpose	16	USB Play Mode	36
Pitch – Fine Tuning	17	USB Play Speed	36
Auto Accompaniment Section	18	USB Play Volume	36
Favorite Style Group	18	USB Mute Track	37
Select A Style	20	Local Midi	38
Auto Chord Recognition	20	USB Midi In	38
Auto Accompaniment	20	USB Midi Out	38
Start/Stop	20	Teacher Duet	39
Fill In 1 And Fill In 2 - Style A/B Variations	22	Sustain Pedal	39
Syncro/Key Start	22	Bluetooth	40
How To Select Auto Start	22	Reset	40
Intro/Ending	22	Auto Power Off	41
Tap Tempo	22	Direct Reset	42
Auto Accompaniment On/Off	22	Connections	43
Auto Setup	22	Sound List	44
Full Keyboard	23	Style List	52
Metronome	23	Midi Implementation chart	60
Metronome Volume	24		
Tempo Control	24		
Auto Accompaniment	24		



KEY ACTION TECHNOLOGIES SINCE 1956

---

## DECLARATION

---

**1612001**

This certificate is issued by **FATAR Srl** having principal place of business in Via Volponi - Zona Industriale Squartabue, 62019 Recanati (MC) - ITALY.

Brand:

**ORLA**

Models:

**Grand 120, Grand 500**

Object:

**We certify that the products listed above use the keyboard mechanism denominated TP/40GH, developed and produced by FATAR in accordance with its quality standards.**

The keyboard TP/40GH has been developed to offer a solid and professional touch, providing an authentic and precise performance. The four zones of graded hammer action and the return spring application create the right combination to give the feeling of a real acoustic piano.

The use of this keyboard mechanism in association with the products here certified can be identified through the logo "**FATAR GRAND TOUCH**".



Place and date of issue: Recanati - ITALY, 13th December 2016

**FEDERICA CELLI**  
Sales Manager

A handwritten signature in black ink, appearing to read 'Federica Celli', written over a horizontal line.

**MARCO RAGNI**  
President

A handwritten signature in black ink, appearing to read 'Marco Ragni', written over a horizontal line.

**NOTE:**

The use of logo "FATAR GRAND TOUCH" in its different multimedia formats is allowed only and exclusively in association with the products listed in this certificate. Any other use is punishable by the law.

FATAR © is a registered trademark and all rights are reserved.

# SAFETY PRECAUTIONS AND INSTRUCTIONS

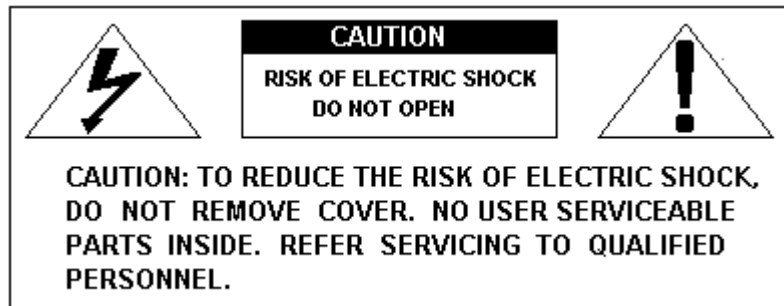

## WARNING

This piano has a global power supply allowing its use in various countries and comes, typically, with a polarized cable (three prong AC power cable).

When using electric pianos, always follow basic precautions, including the following:

1. Read these instructions completely before using your piano.
2. To reduce the risk of injury, close supervision is suggested when the piano is used near or by children.
3. Do not use this piano near open water or excessive moisture. For example; near a bathtub, washbowl, kitchen sink, a wet basement, near a swimming pool, or the like.
4. This piano, either alone or in combination with an external amplifier, headphones, or external speakers, may be capable of producing sound levels that could cause permanent hearing loss. Do not operate for long periods at high-volume levels, or at a level that is uncomfortable.
5. This piano should be placed in a well-ventilated location away from excessive external heat sources.
6. This piano should never be operated with a power supply other than the one originally supplied.
7. This piano is equipped with a polarized (three prong) plug. This is a safety feature. If you are unable to insert the plug into the outlet, contact an electrician to replace your obsolete outlet. Do not defeat the safety purpose of the plug. Do not modify the plug provided with the piano - if it will not fit - have a proper outlet installed by a qualified electrician.
8. The power-supply cable of the piano should be unplugged from the outlet when left unused for a long period. When re-plugging unit, turn on the instrument and leave on for 3-5 hours to recharge internal battery. The battery may need to be replaced after two or three years of use.
9. Care should be taken so that objects do not fall, and liquids are not spilled, into the cabinet through openings or between keys.
10. The piano should be serviced by qualified personnel when:
  - a. the power-supply cord or the plug has been damaged.
  - b. Objects have fallen, or liquid has been spilled, into the piano
  - c. The piano has been exposed to rain or excessive moisture.
  - d. The piano does not appear to operate normally, or exhibits a marked change in performance.
  - e. The piano has been dropped, or the cabinet damaged

### **This Owner's Manual Disclaimer**

The messages contained in the actual display may not always match the display examples on these pages. They may be a representation of the many features of the piano.

Due to the constant effort to improve the piano, the piano specifications might differ to those in the manual. The specifications are subject to modification without prior notice.

### **TAKING CARE OF YOUR INSTRUMENT**

Your instrument is a fine instrument and deserves careful treatment.

Follow carefully the next few points, to keep it at its best for many years.

1. Never open the case and touch the internal circuits.
2. Always switch the power Off after use.
3. Use a cloth or a damp sponge. If the dirt is particularly persistent, use a neutral detergent to remove it. Never use solvents or alcohol.
4. Do not place your instrument near electric motors, neon or fluorescent lamps as these may generate disturbances.
5. In some cases, you may need to change the position of the instrument to avoid interference.
6. Keep your instrument away from dusty environments, high humidity, and high temperatures.
7. Avoid plugging in additional appliances and other electronic equipment into the same outlet.
8. Before turning on the piano, make sure that any external amplifier and speaker system that you have connected to your instrument are turned off.
9. Computer controlled instruments can be interrupted by spikes, surges and dropouts on the power line. If your instrument stops working because of a power line disturbance, switch it off for a few seconds and then switch it on again.
10. Never disconnect the power cable without turning the power switch off.

# GETTING STARTED

## PREPARATION

This section contains information about setting up your instrument and preparing to play. Be sure to go through this section carefully before using this instrument.

## POWER SUPPLY

Many electronics today include external power supplies. This piano includes an internal power supply requiring you take the included power cable and insert the polarized three prong AC plug into the closest, convenient, AC wall socket. Plug the other end into the special receptacle under the left side of the keyboard. You can't do this wrong. It will only plug in one way.

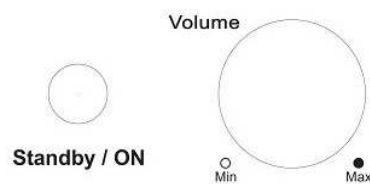

1. Turn on the instrument by pressing the Standby ON switch located in the left of the front panel.
2. Set the Master VOLUME to the desired level. The Master VOLUME controls the overall volume for the entire instrument. Suggest starting at half position.

## HEADPHONES

This piano includes two stereo headphone jacks. One can be used for playing privately without disturbing anyone and two can be used to play privately with a teacher or duets with another player. They can be used individually or together. The internal speaker system is automatically switched off, when the headphone is plugged into the PHONE socket.

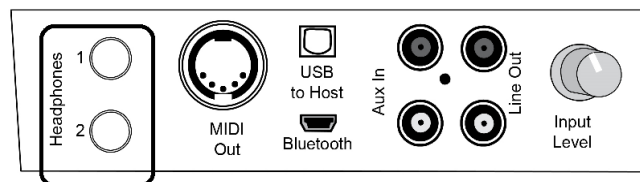

This panel is attached facing toward the bench in plain sight on the underside of the keyboard to the left.

## BLUETOOTH AUDIO CONNECTION

It is possible to wirelessly connect your piano to a Bluetooth capable remote audio device including Smart Phones, or Tablet, or computers using the optional BT1 Bluetooth audio RECEIVER or similar Bluetooth audio receivers. The optional BT-1 can be connected in the Bluetooth socket or other devices can be connected to the audio inputs on the connections panel under the left side of the keyboard..

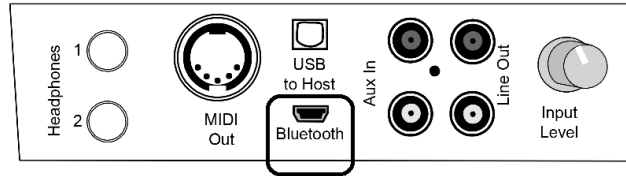

Once you have your Bluetooth receiver “paired” (wirelessly connected), with your Bluetooth capable phone/tablet/computer, a whole world of internet based fun and education, with your available WiFi or phone data becomes available.

Once connected and wirelessly paired, there are many possibilities.

1. Play your favorite music through the high quality sound system of your piano just as you would a stereo with thousands of songs available for free on the internet.
2. Play along with your favorite artists and musicians. The piano is fully functional while you are playing music through your Bluetooth connection. Notice the “Input Level” knob on the connection panel that allows you to adjust the balance between your piano and the music being played from your Bluetooth connection.
3. Don’t forget that audio is the “sound” half of video. Watch videos through your Bluetooth capable device while listening through your piano. Watch and play with your favorite artists or take piano lessons or other online lessons and more.

Setting up and connecting or “pairing” you Bluetooth receiver varies with the model Bluetooth you receive. Follow the instructions that come with your Bluetooth receiver.

## PLAYING DEMO SONGS

Your piano comes equipped with a complete selection of songs arranged to demonstrate a broad selection of Voices (Or Sounds) and Styles (Or Rhythms) in your piano.

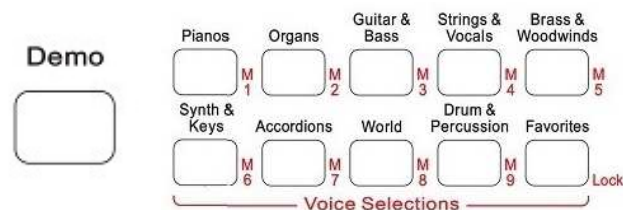

- Press the DEMO button. All the VOICE and STYLE SELECTION buttons will start blinking.
- Press the PIANO button and the Piano Demo Song will start playing. At the end of the Piano Demo, the song will stop and all the buttons will start blinking again.
- Press the ORGAN button to select the Organ Demo Song.
- Continue auditioning all the voices and styles to familiarize yourself with the potential of your Digital Piano



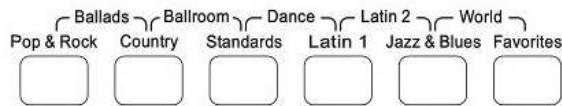

- Press the POP&ROCK button and the Demo Song will start playing using one of the styles of the POP&ROCK section. At the end of the Demo, the song will stop and all the buttons will start blinking again.
- Press the POP&ROCK and the COUNTRY button at the same time to select the BALLADS Demo Song.
- Follow the above instruction to play all the Demo Songs related to the Style Selection buttons.

The Demo function can be stopped by pressing the DEMO button again even while the Demo is playing.

### SOFT/SOSTENUTO/SUSTAIN PEDAL

Insert the Pedals Cable to the dedicated connection – near the power cable connector -. This instrument’s pedals work with a set of three pedals giving the following functions:

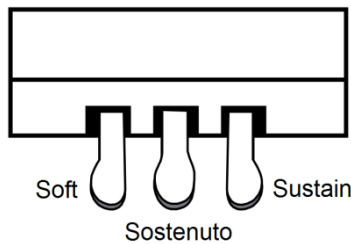

- SOFT:** gives the piano voices a "softer" sound.
- SOSTENUTO:** Sustains only the keys held on the keyboard before the Sostenuto pedal is depressed. All other keys played after the Sostenuto is depressed will sustain as usual.
- SUSTAIN:** Depressing this pedal allows all note played to sound or sing freely, even when the keys are released.

### Programable Sustain Pedal (Half Sustain)

- Press the FUNCTION button and, with the data Control Wheel, scroll to the Half Sustain page. The half pedal function emulates how the sustain pedal works on an acoustic concert grand piano. Many Sustain pedals on digital pianos are just “on/off”. This function is important for a serious player or student.



Notice that, when using the “Function” button, the first line in the two-line display remains in its default purpose, indicating the selected voice. (You may notice “Grand Piano 1” is a popular one.)

The second line, indicates the function “in play”. Turning the Data Wheel will scroll from (function name) to “ON” or “OFF”. This will either turn the function on or off or change its value. This status or value is shown on the second line in the display to the left of the colon. Pressing the “Enter” button will “engage” the value you have scrolled to in the display.

001 : Grand Piano1  
ON : HalfSustain

- Using the Data Control Wheel, it is possible to change the Half Sustain On/Off setting

001 : Grand Piano1  
Off : Half Sustain

### **Programable Sustain pedal (Expression Pedal)**

Your piano will play as multiple instruments including organs. A basic component of an organ is an “expression pedal” which allows you to control the volume of your performance with your foot. The sustain pedal function can be changed to operate as an expression pedal under the “function” menu.

- Press the FUNCTION button and with the data Control Wheel select the Half Sustain page

001 : Grand Piano1  
Half Sustain

- Using the Data Control Wheel it is possible to change the Half Sustain page to the Expression Pedal.

001 : Grand Piano1  
Expression Pedal

- Because your digital piano allows you to play many more instruments than just piano, you can change the function and behaviour of the keys and pedals to emulate those of other instruments.
- The organ is the best example of this. The traditional organ does not have or use the sustain function as a piano does. The organ, typically doesn’t have or use a sustain pedal. It does, however, use an expression pedal. Think of an expression pedal as a volume control.
- In this configuration, the Sustain Pedal is working as Expression/Volume pedal in the instrument.

## VOLUME & Tone Controls

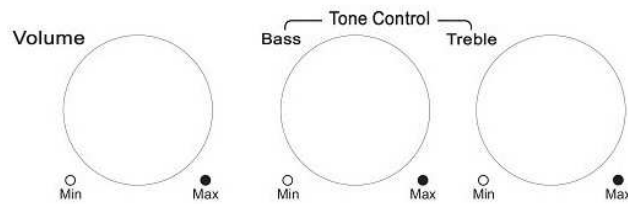

The Master Volume & Tone Controls the overall volume and tone or brightness of the sound.

## SELECTING AND PLAYING THE VOICES (Sounds)

Your instrument has 354 sounds in the internal sound library, and 10 Drum Kits. (A drum kit is a group of percussive instruments common to a style of music.)

The available sounds can be played or assigned to three different modes: Main Sound, Layer Sound, Left Sound.

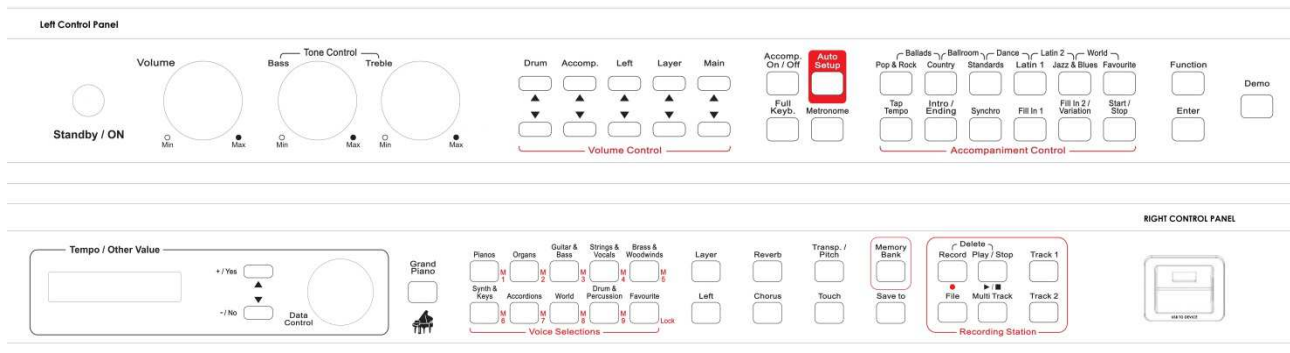

The best digital pianos will not only allow you to select and combine many different voices. It will also allow you to “assign” voices to different areas of the keyboard. This ability allows you to control and play more content. Think of a drum kit where many different drums are played by one person. Many drum voices to choose from and many methods to control them.

- MAIN - plays a single voice over the entire range of the keyboard.
- LAYER - mixes two different voices together for rich, complex sounds.
- LEFT - allows to select one sound for the Left part and up to two sounds for the Right part of the keyboard.

The complete list of the available Voices or Sounds is available in the SOUND LIST pages at the end of this manual. (Page 44)

## SOUND SELECT

Because your digital piano provides so many voices and styles we have devised a clever way to find and select them quickly and easily.

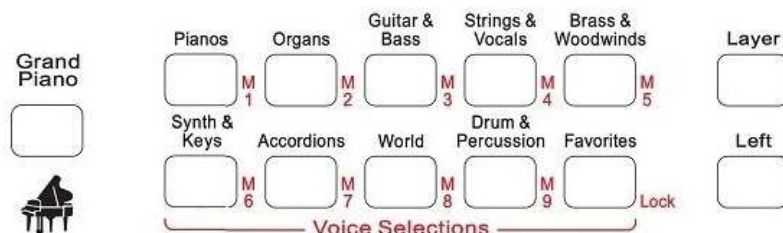

The sounds are listed in 9 Voice Families:

PIANOS (001-039)	The best assortment of Acoustic, Digital/Electric Piano sounds.
ORGANS (040-082)	A nice selection of Jazz, Pop and Church and chapel Organs
GUITAR&BASSES (083-142)	Electric, Acoustic Guitar and basses
STRINGS&VOCALS (143-185)	The perfect Strings Orchestra or Choir you may desire
BRASS&WOODWIND (186-244)	All the Big Band sounds and solos
SYNTH&KEYS (245-279)	A touch of modern music
ACCORDIONS (280-319)	Simply the best reed sounds
WORLD (320-330)	A taste of International Music
DRUM&PERCUSSIONS(331-362)	A box full of rhythm
FAVORITES	Your Favourite sound selection

## MAIN VOICE

To select a Piano sound from the PIANOS section as the Main Voice – make sure that the LAYER and LEFT buttons are switched Off - just push the PIANOS button and a nice Piano sound will be available on the full keyboard and the related sound name will be indicated on the display

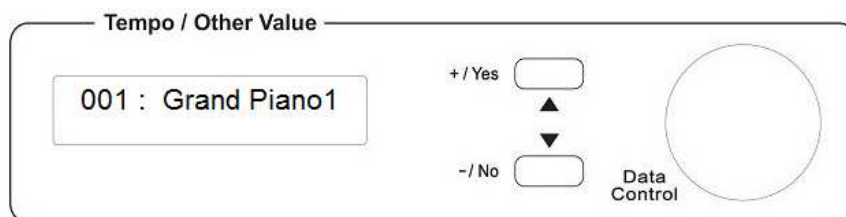

There are many voices or sounds in every voice family or category. After choosing a voice family you can scroll through the available voices using the “data control wheel” Simply stop on your choice and play.

Use this procedure for each voice family.

## LAYER VOICE

It is possible to select two voices to be played as a combination using the “LAYER” feature to obtain richer and fuller sound for the instrument for example, Piano and Strings.

- Select a Piano sound (Or main voice)
- Press now the LAYER button to access or find the second Voice – its Led is now On -.

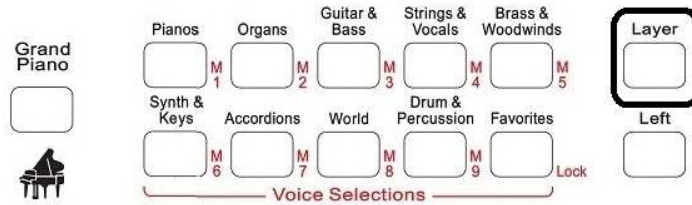

- Press the STRINGS&VOCALS family button to find or access the available sounds of the family.

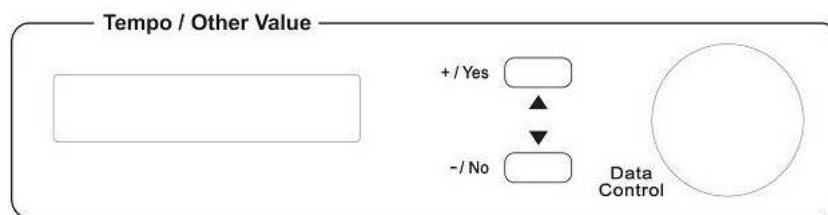

- Using the Data Control Wheel, scroll through the Strings and Vocals sounds available in the that family and select the desired Voice. The related voice name will be indicated on the display
- You now have a “layered or duel” voice available on the instrument. Piano and Strings

## LEFT VOICE

Because of the versatility of your digital piano, you can set up and play a full musical ensemble by choosing and assigning one instrument like the piano (your choice) to the right hand while assigning another to the left hand, like organ (or bass guitar). Add some drums and you are the band!

- Press the LEFT button to access to the Left Voice section – its Led is now On -.

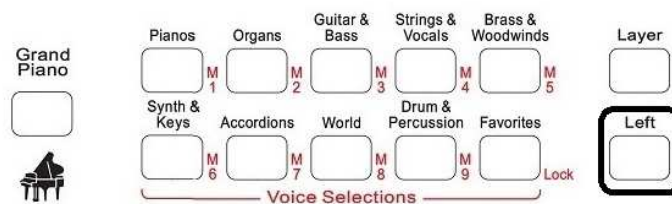

- Press, for example the ORGANS button to access the available sounds of the family.

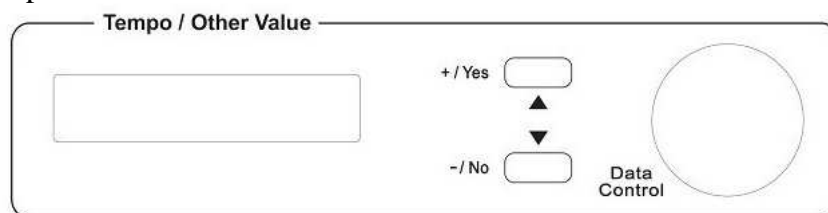

- Using the Data Control Wheel, scroll all the Organs sounds available in the family button and select the desired Voice. The related voice name will be indicated on the display
- You have now available on the instrument a nice Organ voice playing on the Left part of the keyboard.

## SOUND VOLUME

The volume of each section can be controlled with the related volume buttons.

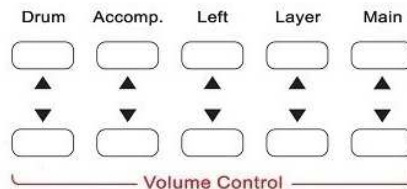

- The DRUM buttons will control the volume of the Drums and Percussion instruments of the Styles.
- The ACCOMP. buttons will control the Auto Accompaniment volume.
- The LEFT buttons will control the volume of the Left Voice.
- The LAYER buttons will control the volume (or balance) of the Layer Voice.
- The MAIN buttons will control the volume of the Main Voice.

When you adjust the volume or “balance” of each section its level is represented in the display with a number from 00 (no sound) to 127 (maximum volume).

## GRAND PIANO BUTTON

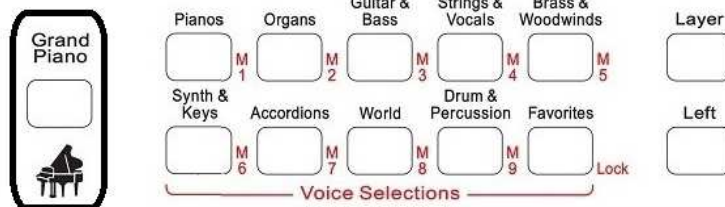

As you can see, your piano is highly programmable with many custom adjustments and selections you can make. As nice as this is, for many, the most important instrument is the piano and the Grand Piano button will get you back home to the piano with just one button push. It does more than simply choose a piano voice. It returns all the settings to a place where the entire instrument returns to the operating mode of a traditional piano including keys, pedal and best settings. Simple and fast!

## Using your FAVORITE VOICE Function

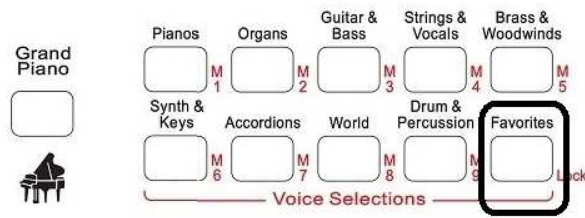

Your piano offers a large selection of sounds in the many Voice Families available. However, we all develop our favorites and use them most often and like to have fast and easy access to them. You may store your favorite voices under on button. The “Favorites” button. Up to 25 of them.

Choosing (storing) your favorites voices:

- Select on the display the sound in any of the available Voice Families
- Press and hold the FAVORITE button in the Voice Selections section
- Press the YES button to confirm the selection and to add the sound to the list.

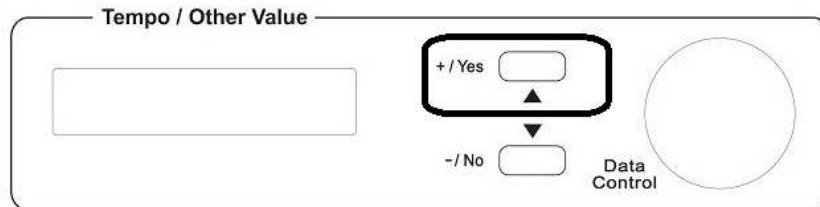

- Release the FAVORITE button. The selected sound is now stored in the Favorite Voice Family.

## Changing your Favorite Voice Family

It is possible to repeat the above sequence to store up to 25 different sounds in the Favorite button. If you would like to change the Favorite Voice family list and delete one or more stored sounds, here is the procedure:

- Press the FAVORITE button and select on the display the sound you like to cancel.
- Press and hold the FAVORITE button in the Voice Selections section
- Press the NO button to delete the sound from the list

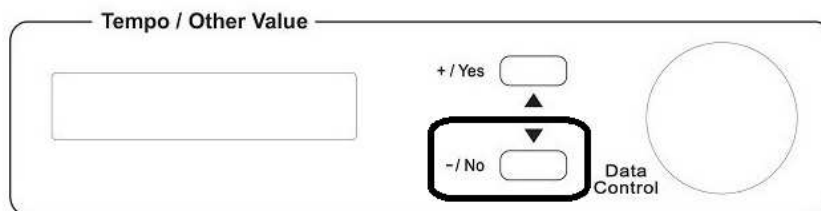

- Release the FAVORITE button. The selected sound is now cancelled from the Favorite Voice Family.

You make these changes whenever you like.

## SELECT THE SPLIT POINT

Because your piano is an “ensemble” piano, there are many special functions that will occur on the left side of the keyboard starting on a particular key, progressing to the left. Where this happens is programable. (This is called the “split point”)

The default position of the Split point is F3#. (Counting from the left, the third octave of the F# Key)

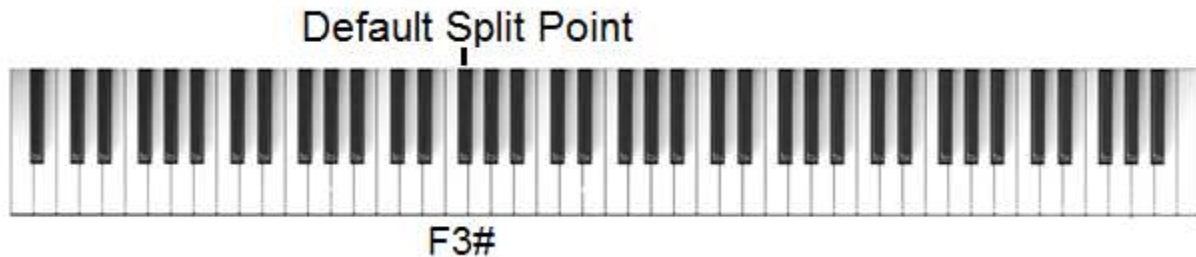

The Split Point (or CHORD POINT) can be set to any other key as follows:

- Press and hold the LEFT button and the display will indicate:

001 : Grand Piano1  
55 : Chord Point

55 is the corresponding value to F3# note. (55, Counting from the right)

- Using the Data Control wheel it is possible to select a different value for the Split/Chord point. The display will return to the normal display mode and the new Split/Chord Point is now set.
- The Split/Chord point will be restored at F3# (value 55) at power up.

## DIGITAL REVERB

The Reverb simulates the effect of playing in a big room or a hall where the sound reverberates off the walls and ceiling. The reverb effect is automatically selected when the piano is turned on.



Press the REVERB button to turn the reverb effect Off and the indicator will go out. Switch the reverb feature On and Off by pressing the REVERB button.

There are eight reverb effects available:

1-Hall, 2-Hall2, 3-Room1, 4-Room2, 5-Room3, 6-Stage1, 7-Stage2 and 8-Plate.

- Press the REVERB button On and the reverb type is shown in the display.

001 : Grand Piano1  
5 : Room3



- Use the DATA WHEEL to select a different reverb type.

The reverb level for the Main, Left and Layer voices can be changed in the Function menu, please see the Function section of this manual for more information. (Page 31)

## CHORUS EFFECT

The Chorus effect adds the impression of depth and spaciousness to the selected keyboard voice.



Press the CHORUS button to engage the chorus effect and the indicator will light up. Press the button again to turn off the chorus effect.

There are eight reverb effects available:

1-Chorus1,	2-Chorus2,	3-Chorus3,	4-Feedback,
5-Flanger1,	6-Short Delay,	7-Short DelayFb	8-Flanger2.

- Press the CHORUS button On, so that the chorus type is shown in the display

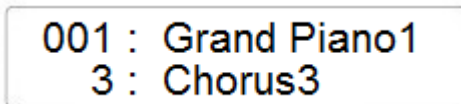

- Use the +/YES, -/NO buttons or the DATA WHEEL to select a chorus type.

The chorus level for the Main, Left and Layer voices can be changed in the function menu. Please see the Function section for more information. (Page 32)

## TOUCH SENSITIVITY

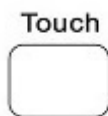

Just like an acoustic piano, your instrument has an 88 note keyboard with velocity control. This means the level of the audio signal will be in proportion with the velocity with which the key is pressed. If you play soft you will have a quiet sound, while if you play very hard you will have a much louder sound .

Unlike an acoustic piano, you can customized the strength it takes to play this piano effectively, A younger, weaker hand might prefer a "soft" touch?

The TOUCH button allows you to select 3 different touch sensitivity curves:

- |            |   |
|------------|---|
| 1 - HARD   | This setting requires the keys to be played quite hard to produce maximum loudness. |
| 2 - NORMAL | This setting produces standard keyboard response. This is the factory default mode. |

### 3 - SOFT

This setting allows maximum volume with light key pressure.

To select the Touch Sensitivity you desired press the TOUCH button and the display will show:

001 : Grand Piano1  
2 : TouchNormal

Using the Data Control wheel, it is possible to select the other different touch sensitivity curves available in the instrument:

001 : Grand Piano1  
1 : TouchHard

001 : Grand Piano1  
3 : TouchSoft

At Power Up the NORMAL curve will be automatically switched ON.

When TOUCH button is switched Off, the keyboard will play without touch sensitivity at the fixed midi value of 100. The display will show:

001 : Grand Piano1  
100 : FixTouch

Using the Data Control wheel it is possible to change the FixTouch value from 0 (no sound) to 127 (maximum volume).

## TRANSPOSE

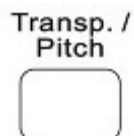

It is possible to Transpose the natural key ( C ) of your instrument up or down as follows:

- press the TRANSPOSE button in the FUNCTIONS section.
- The TRANSPOSE button will start blinking and the display will show:
- 

001 : Grand Piano1  
0 : Transpose

Using the Data Control wheel, it is possible to transpose the instrument in the desired key according to the following table

C	C#	D	D#	E	F	F#	G	G#	A	A#	B	C	C#	D	D#	E	F	F#	G	G#	A	A#	B	C
-12	-11	-10	-9	-8	-7	-6	-5	-4	-3	-2	-1	0	1	2	3	4	5	6	7	8	9	10	11	12

At Power Up the instrument returns automatically to the original tuning.

The ability to transpose is another function that comes with your digital piano. Transposing is typically done to raise or lower the range of a song to get into a more comfortable range for a singer. Accomplishing this on an acoustic piano often requires years of training and experience on the part of the musician. Many musicians feel that transposing from the original “key” can bring new qualities to a composition. Few musicians are able to do this on the fly but you are with your digital piano.

### PITCH – Fine Tuning

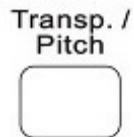

In those cases where transposition by semitones is not enough, and a more accurate tuning is necessary, it is still possible to change pitch.

Push and hold the TRANSPOSE button until the display shows:



Using the Data Control wheel, it is possible to change the natural pitch of the instrument up to 63 cents and down to 64 cents.

At Power Up the instrument returns to the original tuning.

Changing the pitch is a function seldom used but is a wonderful tool when needed. Not all acoustic instruments have the tuning stability of your digital piano. If you ever play with another instrument that is “off” you can adjust your piano to meet match their pitch.

## AUTO ACCOMPANIMENT SECTION

Your piano has an auto accompaniment function that may surprise you. A built-in computer will allow you to play with a simple left hand chord or just a single note and your piano will play a complete arrangement allowing you to play the melody and other materials with your right hand. Once you understand how it works you can take full advantage of this extremely fun and satisfying feature.

Your instrument has 350 accompaniment styles which can be used to provide fully-orchestrated Auto Accompaniment patterns.

The styles are listed by Styles Families and divided in 10 different groups. In each group, you will find a wide selection of styles that will offer you the best solution for every song you want to play.

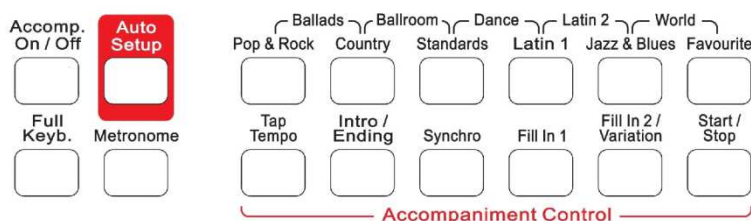

There is a total of eleven style families including a programmable “Favorites” location. These can be selected by pressing the related button. These include Pop&Rock, Country, Standards, Latin 1, Jazz&Blues and Favorites.

To select the other five style families- Ballads, Ballroom, Dance, Latin 2, and World, press the two buttons graphically linked buttons underneath the family you want to use.

An example would be to press the Pop& Rock button together with the Country button to select the “Ballads” Style Family. You will see the That family name appear in the display.

## FAVORITE STYLE GROUP

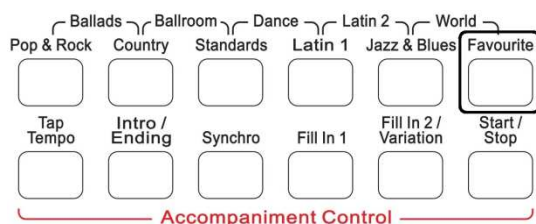

With as many as 350 styles, you have a huge library to sort through and use. The programmable “Favorites” family allows you to keep your most used and appreciated styles close at hand. You may collect up to 25 styles in this group.

Adding a desired style to the Favorites Group:

- Select a style as usual.
- Press and hold the FAVORITE button in the Accompaniment Control section
- Press the YES button to confirm the selection and to add the style to the list.

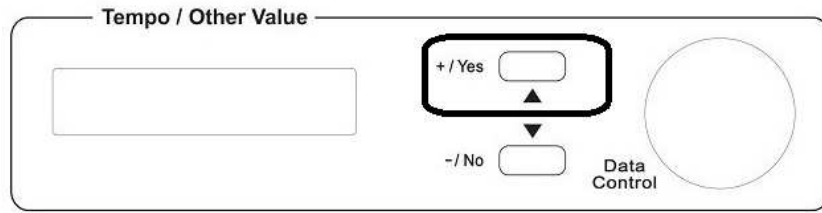

- Release the FAVORITE button. The selected style is now stored in the Favorite Style Family.

It is possible to repeat the above sequence to store up to a total of 25 different styles in the Favorite group.

If you would like to change the Favorite Style family list you must delete one to make room for your new addition. Here's how to do that.

- Press the FAVORITE button and select on the display the style you like to cancel.
- Press and hold the FAVORITE button in the Accompaniment Control section
- Press the NO button to delete the style from the list

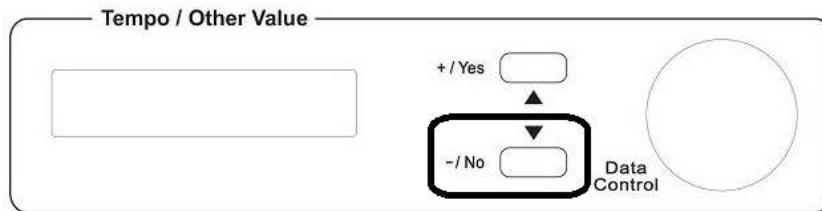

- Release the FAVORITE button. The selected style is now cancelled from the Favorite Style Family.

It is possible to repeat the above sequence to cancel more styles from the Favorite group.

Press the “Accomp. On/ Off” button to turn on the Auto Accompaniment function.

When turned on, the keyboard will be “split” or “mapped for the left side of the keyboard to be used to play automatic accompaniments with orchestrated chords and bass lines and drums.

The right part of the keyboard is available for playing the melody.

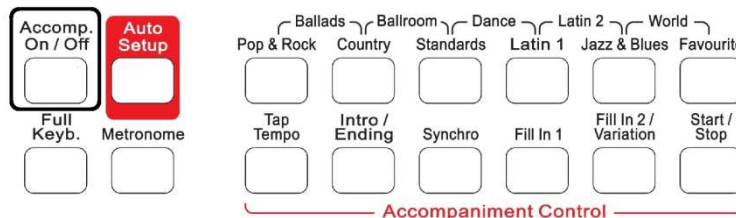

## SELECT A STYLE

To select a Style just push the desired Style family button, for example Country. A nice Country Style will be selected and indicated on the display.

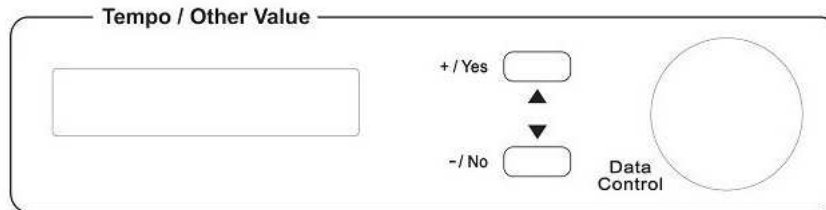

It is possible now to select from the many Country styles available in this style group using the Data Control Wheel, scrolling all the Country styles available in the Country family button.

## AUTO CHORD RECOGNITION

When playing the Auto accompaniment, it is possible to change chords using one or more fingers without selecting the One Finger Note system or the Multi Finger Chord system. The internal computer will automatically select it for you.

## AUTO ACCOMPANIMENT SELECT AND CONTROLS

A different accompaniment style can be selected at any time while the accompaniment is playing. The style name on the Display will change as soon as the selection is made, but the new style will start from the beginning of the next bar. (On the “downbeat”) If the Auto Set Up function is not activated; the tempo will not change when the new style is running.

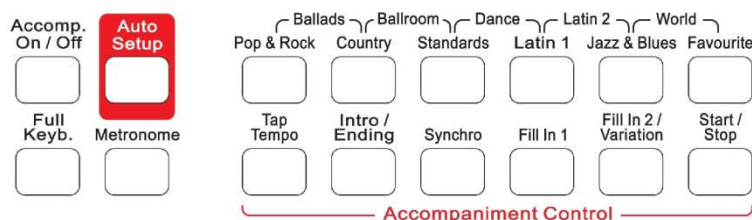

Your instrument provides a range of accompaniment features:

**Start/Stop, Fill-In 1, Fill-In 2, Syncro Start, Intro/Ending, Tap Tempo, Accomp. On/Off, Auto Setup, Full Keyboard, Metronome**

## START/STOP

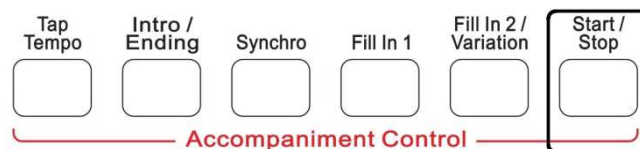

The START/STOP button starts the selected accompaniment style or selected rhythm immediately. Without the auto accompaniment button on it starts and stops the drums, Press the ACCOMP. ON/OFF button to turn the Auto Accompaniment On before starting the style. The accompaniment will start with the rhythm drum sound when the START/STOP button is pressed, then the bass and chord parts will play as soon as the first note or chord is played on the

keyboard from F3 below which is the default split for notes that “trigger” the auto-accompaniment function.

### FILL IN 1 and FILL IN 2 - STYLE A/B VARIATIONS

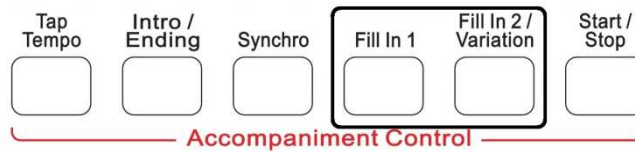

A fill in provide a “break” or interplay with the main rhythm pattern providing variety and interest. There are 2 variations or versions of “fills” available for each style: Variation A and Variation B. Press the Fill 1 to select Variation 1 and press Fill 2 to select Variation 2.

The Auto Accompaniment pattern changes depending on the chords you play with your left hand. The FILL IN buttons let you add dynamic variations and breaks in the auto style, to make your performance sound more professional. At the end of the fill-in the appropriate Style Variation is automatically selected.

The fill-in will play when selected as long as one of the fill-in buttons is pressed.

### SYNCRO/KEY START

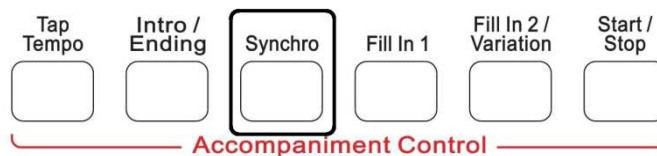

There are two types of Auto Start features:

- **SYNCHRO START**      When this feature is selected the Auto Start will automatically start the style when the first key or chord is pressed and it will stop when the STOP button or the ENDING button is selected.
- **KEY START**      When this feature is selected the Auto Start will automatically start the style when the first key or chord is pressed and automatically stop the style when the key or chord is released.

### HOW TO SELECT AUTO START

Press and hold the SYNCHRO button and the display will indicate:

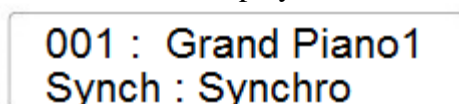

- Using the Data Control Wheel select Synchro Start or Key Start feature as desired.

## INTRO/ENDING

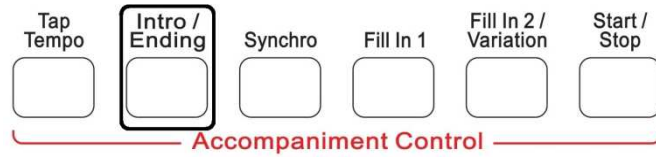

If you press this button before you start the rhythm, the normal rhythm pattern will be preceded by a special introduction (INTRO). However, if you press the button when the rhythm is already running, the instrument plays a final variation (ENDING) and the rhythm section will stop automatically.

All accompaniment patterns can be started with an appropriate introduction by pressing the INTRO/ENDING button, once the style has been selected. When the INTRO finishes playing, the accompaniment will change to the main style pattern.

If the SYNCHRO button and then the INTRO/ENDING button, the accompaniment will start from the introduction as soon as a chord is detected.

## TAP TEMPO

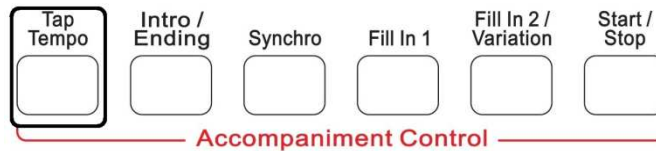

This function allows you to set the rhythm tempo by tapping in tempo on the [TAP] button.

Tap on the button while rhythm playing and the the rhythm tempo will automatically set at the speed you are tapping.

To set the time signature before starting rhythm, tap on the button 4 times for a 4/4 beat, 3 times for a 3/4 beat.

## AUTO ACCOMPANIMENT ON/OFF



Press ACCOMP. ON/OFF button to activate the Auto Accompaniment feature. The Led it is now On. Press it again to deactivate.

## AUTO SETUP



The word “registration” comes from the organ and refers to all the voices, tempos, and setting used with a song. Some instruments are more appropriate with different types of music. Tuba may not be as popular with Pop & Rock, for example.



This function enables the instrument to set an appropriate registration for each rhythm. When a style is selected and the “Auto Setup” is activated - its Led is now On -, a nice registration for both the left hand and right hand parts will be automatically selected. The Auto Setup will also select the optimum tempo for the style selected. An indicator illuminates in the Display when the system is activated. When the registration is changed with the Auto Setup activated, the instrument will accept the changes but the registration will not be changed in the internal memory. A good way to start exploring the instrument is to listen to the Auto Setup registrations. By selecting the desired rhythm with the Auto Setup system ON, you will hear 350 nice registrations. The Auto Setup system can be switched ON and OFF by pressing the Auto Setup button.

## FULL KEYBOARD



A great way for the piano player in the family to use and become familiar with the auto accompaniment system is “Full Keyboard mode” You just play as you would an acoustic piano and your digital piano will play along. This feature allows you to play automatic chords in the full length of the keyboard. Press the button to activate the feature. When in full keyboard, the chords played by the Auto Accompaniment System will not be displayed on the screen.

## METRONOME

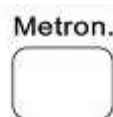

A metronome is an excellent tool for students and, sometimes, required by teachers. Instead of an extra cost device, a remarkable metronome comes standard with your digital piano. The Metronome is a convenient feature for practice, and it can also provide a rhythmic guide when recording. To start your metronome, Press the “metronome button and press again to turn off.

The best metronomes will not only click the tempo but will also indicate the down beats in various time signatures.

To select the desired Time Signature of the metronome:

- Press and hold the METRONOME button. The display will indicate:



- While still holding the METRONOME button, the display indicates the currently selected time signature (Time Sign.).

001 : Grand Piano1  
4/4 : Time Sign

- Still hold the METRONOME button and using the Control Data Wheel select the new Time Signature if necessary from the following list:
- (1/4, 2/4, 3/4, 4/4, 5/4, 6/4, 3/8, 6/8, 7/8, 9/8, 12/8 )
- To change the Metronome speed use the TEMPO  $\wedge$  and  $\vee$  buttons.

### METRONOME VOLUME

- Press the FUNCTION button and with the data Control Wheel select the Metronome Volume page

001 : Grand Piano1  
Metronome Vol

- Press the ENTER button to confirm and the display will indicate the current Metronome Volume

001 : Grand Piano1  
100 : Metro Vol

- Using the Data Control Wheel it is possible to change the value (range 0 – 127)

### TEMPO CONTROL

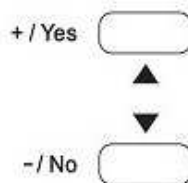

In music, the tempo speed is indicated by “BPM” (Beats per minutes)

The [-TEMPO+] buttons can be used to control the tempo of the Auto Accompaniment section, the DEMO songs and the record/play back of a song recording.

Press the [-TEMPO+] buttons to set the desired tempo value (20-280). The current tempo (beats per minute) will appear on the Message Display.

The instrument also offers the ability to input TEMPO settings via the [+/-] buttons.

Press the [TEMPO+] and [TEMPO-] buttons simultaneously to restore the default tempo setting of the selected style.

### AUTO CHORD - Auto Accompaniment TYPE

It is possible to play the instrument in Multi Finger Mode (Fingered) or in Single Finger Mode.

To select one of the two auto chord types:

- Press the FUNCTION button and using the Data Control Wheel select the CHORD TYPE page on the display

001 : Grand Piano1  
Chord Type

- Press the ENTER button and the display will indicate:

001 : Grand Piano1  
2 : Fingered

- to select the Single Finger Mode use the Data Control Wheel.

### SINGLE FINGER MODE

SINGLE FINGER Mode fingering makes it simple to produce beautifully orchestrated accompaniment using major , seventh , minor and minor-seventh chords by pressing a minimum number of keys in the Auto Accompaniment section of the keyboard.

C Major

Press the key C.

C minor

Press the key C + any black key to the left

C Seventh

Press the key C + any white key to the left

C minor 7th

Press the key C + any black + any white key to the left

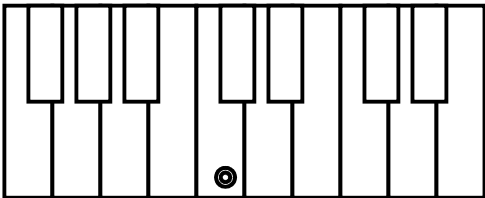

C chord - press C key

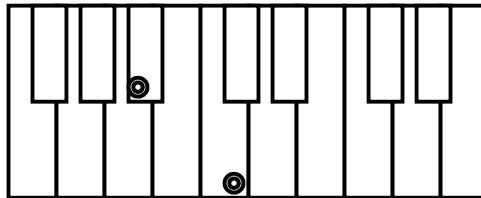

C minor - press C + any black key to left

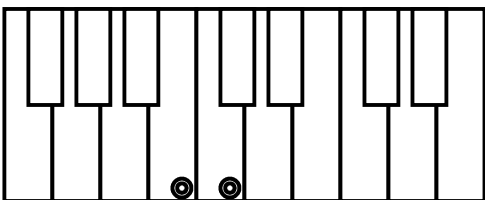

C 7th - press C + any white key to left

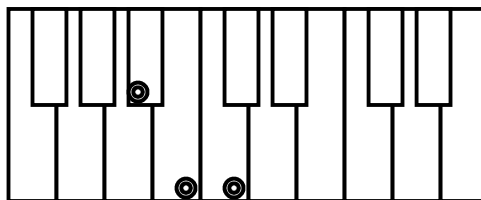

C minor 7th - press C + any black and any white to left

## REGISTRATION MEMORY

Over time, you will find combinations of voices, styles, and settings that you prefer for your favorite songs and playing. Because your keyboard is so versatile and has so many choices, the ability to save for instant recall your favorite setting or “registrations” becomes very useful.

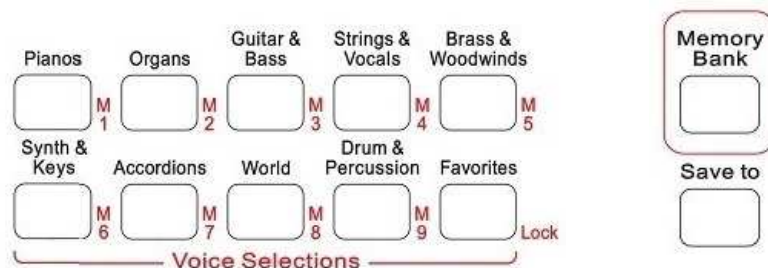

It is possible to load up to 54 panel registrations using the 9 Memory buttons (M1 – M9) and 6 memory banks.

To select a Memory Registration Pre-set just press the related button.

To select the Memory Registration Bank, select the MEMORY BANK button and using the Data Control Wheel select the desired memory Registration Bank number (from 1 to 6).

## HOW TO STORE THE REGISTRATION MEMORIES

To save the single memory positions is very easy.

- Set the instrument with the desired sounds, style, effects, volumes, split point, etc.
- Press and hold the MEMORY BANK button and press the memory button where you need to store the registration (for example M1). The display will indicate:



- It is possible to save up to 9 memory Registrations in each Memory Banks.

## HOW TO SELECT A MEMORY BANK

To select the desired Memory Bank is also very simple.

- Press the MEMORY BANK button On
- Using the Data Control Wheel select the bank number desired (from Bank 1 to Bank 6).

## HOW TO SELECT A MEMORY REGISTRATION

- Press the MEMORY BANK button On
- Select now the desired Memory Registration Pre-set by pressing the related button. The instrument immediately load the settings stored in the internal memory including sounds, effects and styles.

## THE LOCK BUTTON

This is a very useful feature that expands the potential of the Memory Registrations.

By pressing the LOCK button On, the different sounds registrations stored in each one of memory location can be recalled, whilst the style accompaniment settings will be LOCKED to the last selected style.

This enables the player to make changes to the melody part(s) of the music ‘on the fly’. The accompaniment section will remain LOCKED, therefore all levels and other parameters pertaining to this section will remain unchanged.

## USB DISK

It is important to understand what a “MIDI” file is. “MIDI” stands for “MUSIC INDUSTRY DIGITAL INTERFACE”. Unlike much of the music you may have recorded on other devices as audio files like tape recorders or MP3 recorders, MIDI files are recordings of the events that occur as you record. A device that records MIDI files is called a sequencer. It records the “sequence of events. An event might be when a key is played rather than the sound that occurs when it is played. When a MIDI file is played back through a MIDI instrument, it is “playing” the instrument rather than playing back an audio recording. The advantages of this way of recording music are many. Smaller file sizes, editing abilities and changing keys, tempos and more.



When inserting the USB disk (Thumb Drive) in this slot you will notice that the display will immediately indicate the first available file stored in the memory. If it is a new USB thumb drive with no data, the display will indicate – NO FILES.

It is possible to use different type of files in the USB disk:

- 1 Standard Midi File songs
- 2 Panel Registrations Settings

The display will show the files in alphabetic order or related to the numbers indicating the file name.

## PLAY MIDI FILES

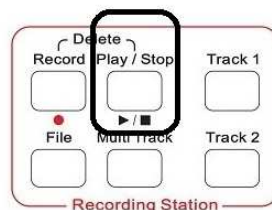

To play the midi files, insert your USB thumb drive with the files and the display will show “DISK IN” and then, the first available midi file.

Select on the display the desired song file on the display using the DATA CONTROL wheel.

Start the song by pressing the PLAY/STOP button. Press PLAY/STOP button again to stop the song.

To return to the Song Select page, after using the instrument with different features, press the FILE button and select on the display the new song file using the Data Control Wheel.

## RECORDING STATION

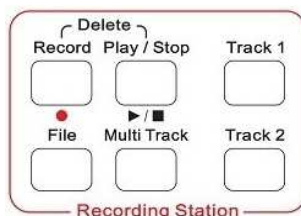

The instrument can record songs as a Standard Midi File.

It is possible to store complete songs in two different systems:

- EASY RECORDING
- MULTI TRACK RECORDING

## EASY RECORDING

It is possible to record a song using one or two tracks using the Track 1 and Track 2 buttons.

Insert the USB disk (lets start with an empty Thumb Drive to make things more easy and clear) in the USB to Device socket.

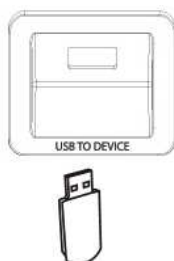

If no USB disk is used, the RECORD system will not work and the display will show

001 : Grand Piano1  
No USB Driver

Before starting the Record procedure, select the sound you want to use for Track 1. It is also possible to use one of the available styles for the Track 1 recording.

- Press the RECORD button and while holding it press the TRACK 1 button.
- It is possible to start now with or without Metronome, with the selected Time Signature as seen in the METRONOME paragraph. Start playing your own music as soon as you are ready, and the Sequencer will start storing the data as soon as the first key is pressed. The display will show

001 : Grand Piano1  
RecTck1

- At the end of your recording just press the RECORD button again to stop the recording of Track 1.
- Track 1 button Led will be On. Record button Led will be Off.
- Press the RECORD button again and while holding it press the TRACK 2 button. Track 1 is On and as soon as the RECORD button will be pressed again, Track1 will start playing and you can record the Track 2.
- Start playing your own music as soon as you are ready, and the Sequencer will start storing the data as soon as the first key is pressed.  
The display will show

001 : Grand Piano1  
RecTrk2

- At the end of your recording just press the RECORD button again to stop the recording of Track 2.
- Track 1 and Track 2 buttons Led will be On. Record button Led will be Off.

Press now the PLAY button to listen to your song.

It is necessary now to store the song just recorded on the USB thumb drive since there is no volatile memory in the piano.

- Press the FILE button (its Led is On)
- Press SAVE to 3 times to access to the Save Track function. The Display will indicate

001 : Grand Piano1  
Save Tck to USB

- Press now the YES button next to the Display to save the song in the USB disk.  
The display indicate

001 : Reg 001  
Save OK

The instrument will save the song automatically with the name Reg\_001, Reg\_oo2....00X

### **MULTI TRACK RECORDING**

- 1 Insert the USB disk in the USB to Device socket.
- 2 Prepare the instrument with the desired style, style features and the desired sound.
- 3 Press the RECORD button to start recording your song – its Led will light up – and play the first track of your Multi Track Song.  
The Display will indicate

Rec : Song01

- 4 Press the RECORD button again to stop recording and the song will be automatically saved with its number Song01

Rec : Song01  
Save OK

- 5 It is now possible to add a second track. Select a new sound and press the RECORD button to access the MULTI TRACK Recording Mode. The display automatically shows:

001: SONG01-1

The Metronome starts counting for the first bar and as soon as the first recorded track starts playing play along the second track.  
At the end of the recording of the second track press the RECORD button to stop recording.  
The display shows:

Rec : Song01 - 1  
Save OK

The two recorded tracks will be stored as SONG01

- 6 To add more tracks repeat the procedure from point number 4. It is possible to save up to 5 tracks.

NOTE – If you desire to save a song using the Main and the Dual Voice in layer mode together with the Split Voice and save them as a multi track song in a single file, just press the RECORD button and start recording, same as in Single Track mode. The instrument will save the file automatically.



## FUNCTION BUTTON

The FUNCTION button is used to access many features hidden in the instrument:

- Main Reverb Level
- Layer Reverb Level
- Left Reverb Level
- Main Chorus Level
- Layer Chorus Level
- Left Chorus Level
- Chord Type
- Metronome Volume
- Main Voice Pan
- Split Voice Pan
- Layer Voice Pan
- Transpose
- Main Octave
- Left Octave
- Layer Octave
- USB Play Mode
- USB Play Speed
- USB Play Volume
- USB Mute track
- Local Midi
- USB Midi In
- Midi Out
- Teacher Duet
- Half Sustain
- Bluetooth
- Reset
- Auto Power Off Time

To access the many available features is very easy.

NOTE: some of the features listed in the FUNCTION button are also accessible directly from some dedicated buttons.

## MAIN VOICE REVERB LEVEL

- Press the FUNCTION button
- The display will indicate the first available feature Main Sound Reverb Level:

001 : Grand Piano1  
Main Rev Lev

- Press the ENTER button to confirm and the display will indicate the current Reverb Level for the Main Sound

001 : Grand Piano1  
18 : MainRevLev

- Using the Data Control Wheel it is possible to change the value (range 0 – 127)

## LAYER VOICE REVERB LEVEL

- Press the FUNCTION button and with the data Control Wheel select the Layer Reverb Level page

001 : Grand Piano1  
Layer Rev Lev

- Press the ENTER button to confirm and the display will indicate the current Reverb Level for the Left Sound

001 : Grand Piano1  
18 : LayerRevLev

- Using the Data Control Wheel it is possible to change the value (range 0 – 127)

### **LEFT VOICE REVERB LEVEL**

- Press the FUNCTION button and with the data Control Wheel select the Left Reverb Level page

001 : Grand Piano1  
Left Rev Lev

- Press the ENTER button to confirm and the display will indicate the current Reverb Level for the Left Sound

001 : Grand Piano1  
18 : LeftRevLev

- Using the Data Control Wheel it is possible to change the value (range 0 – 127)

### **MAIN CHORUS LEVEL**

- Press the FUNCTION button and with the data Control Wheel select the Main Chorus Level page

001 : Grand Piano1  
Main Cho Lev

- Press the ENTER button to confirm and the display will indicate the current Chorus Level for the Main Sound

001 : Grand Piano1  
100 : MainChoLev

- Using the Data Control Wheel it is possible to change the value (range 0 – 127)

### **LAYER CHORUS LEVEL**

- Press the FUNCTION button and with the data Control Wheel select the Layer Chorus Level page

001 : Grand Piano1  
Layer Cho Lev

- Press the ENTER button to confirm and the display will indicate the current Chorus Level for the Layer Sound

001 : Grand Piano1  
100 : LayerChoLev

- Using the Data Control Wheel it is possible to change the value (range 0 – 127)

### **LEFT CHORUS LEVEL**

- Press the FUNCTION button and with the data Control Wheel select the Left Chorus Level page

001 : Grand Piano1  
Left Cho Lev

- Press the ENTER button to confirm and the display will indicate the current Chorus Level for the Left Sound

001 : Grand Piano1  
100 : LeftChoLev

- Using the Data Control Wheel it is possible to change the value (range 0 – 127)

### **CHORD TYPE**

- Press the FUNCTION button and with the data Control Wheel select the Chord Type page

001 : Grand Piano1  
Chord Type

- Press the ENTER button to confirm and the display will indicate the current Chord Type selected

001 : Grand Piano1  
2 : Fingered

- Using the Data Control Wheel it is possible to change the Chord Type to Single Finger

001 : Grand Piano1  
1 : Single

### **METRONOME VOLUME**

- Press the FUNCTION button and with the data Control Wheel select the Metronome Volume page

001 : Grand Piano1  
Metronome Vol

- Press the ENTER button to confirm and the display will indicate the current Metronome Volume

001 : Grand Piano1  
100 : Metro Vol

- Using the Data Control Wheel it is possible to change the value (range 0 – 127)

### **MAIN VOICE PAN**

- Press the FUNCTION button and with the data Control Wheel select the Main Voice Pan page

001 : Grand Piano1  
Main Voice Pan

- Press the ENTER button to confirm and the display will indicate the current Voice Pan value for the Main Sound

001 : Grand Piano1  
0 : Main Pan

- Using the Data Control Wheel it is possible to change the value (range -64 – +63)

### **LAYER VOICE PAN**

- Press the FUNCTION button and with the data Control Wheel select the Layer Voice Pan page

001 : Grand Piano1  
Layer Voice Pan

- Press the ENTER button to confirm and the display will indicate the current Voice Pan value for the Layer Sound

001 : Grand Piano1  
0 : Layer Pan

- Using the Data Control Wheel it is possible to change the value (range -64 – +64)

### **LEFT VOICE PAN**

- Press the FUNCTION button and with the data Control Wheel select the Left Voice Pan page

001 : Grand Piano1  
Left Voice Pan

- Press the ENTER button to confirm and the display will indicate the current Voice Pan value for the Left Sound

001 : Grand Piano1  
0 : Left Pan

- Using the Data Control Wheel it is possible to change the value (range -63 – +64)

### **MAIN VOICE OCTAVE**

- Press the FUNCTION button and with the data Control Wheel select the Main Sound Octave page

001 : Grand Piano1  
Main Octave

- Press the ENTER button to confirm and the display will indicate the current Octave value for the Main Sound

001 : Grand Piano1  
0 : Main Oct

- Using the Data Control Wheel it is possible to change the value (range -2 – +2)

### **LAYER VOICE OCTAVE**

- Press the FUNCTION button and with the data Control Wheel select the Layer Sound Octave page

001 : Grand Piano1  
Layer Octave

- Press the ENTER button to confirm and the display will indicate the current Octave value for the Layer Sound

001 : Grand Piano1  
0 : Layer Oct

- Using the Data Control Wheel it is possible to change the value (range -2 – +2)

### **LEFT VOICE OCTAVE**

- Press the FUNCTION button and with the data Control Wheel select the Left Sound Octave page

001 : Grand Piano1  
Left Octave

- Press the ENTER button to confirm and the display will indicate the current Octave value for the Left Sound

001 : Grand Piano1  
0 : Left Oct

- Using the Data Control Wheel it is possible to change the value (range -63 – +64)

## USB PLAY MODE

- Press the FUNCTION button and with the data Control Wheel select the USB Play Mode page

001 : Grand Piano1  
USB Play Mode

- Press the ENTER button to confirm and the display will indicate the current USB Play Mode setting

001 : Grand Piano1  
1 : Single

- The USB Play Mode setting can be selected as follows:

Single            -            Play All Songs            -            Random

- In Single Mode, only the selected Midi File Song will be played.
  - In Play All Songs Mode, all the Midi File Song of the USB disk will be played as listed in the memory disk.
  - In Random Mode, all the Midi File Song of the USB disk will be played but will be selected in a random mode.
- Using the Data Control Wheel it is possible to select the different Play modes:  
1 - Single            2 - Play All Songs            3 - Random

## USB PLAY SPEED

- Press the FUNCTION button and with the data Control Wheel select the USB Play Speed page

001 : Grand Piano1  
USB Play Speed

- Press the ENTER button to confirm and the display will indicate the current USB Play Speed

001 : Grand Piano1  
100 : USBPlaySpeed

- Using the Data Control Wheel it is possible to change the speed of the SMF song from the USB disk (range 50 – 200)

## USB PLAY VOLUME

- Press the FUNCTION button and with the data Control Wheel select the USB Play Volume page

001 : Grand Piano1  
USB Play Vol

- Press the ENTER button to confirm and the display will indicate the current USB Play Volume value

001 : Grand Piano1  
127 : USB Play Vol

- Using the Data Control Wheel it is possible to change the Volume of the SMF song from the USB disk (range 0 – 127)

### USB MUTE TRACK

- Press the FUNCTION button and with the data Control Wheel select the USB Mute Track page

001 : Grand Piano1  
USB Mute Track

- Press the ENTER button to confirm and the display will indicate the current USB Mute Track selected (there are 16 tracks)

001 : Grand Piano1  
MuteTrack01?

- Press the ENTER button to confirm you want to change the Track 01 NO/YES configuration.  
If NO is selected the Mute Track function will not be active. If YES is selected the Mute Track function will be activated and the track will be muted.

001 : Grand Piano1  
No : Mute Track01

- Select the Mute Track 01 function by selecting YES on the display using the Data Control Wheel

001 : Grand Piano1  
Yes : Mute Track01

- To select now Mute Track 02 select the page on the display

001 : Grand Piano1  
MuteTrack01?

- Select the Mute Track 02 function using the Data Control Wheel

001 : Grand Piano1  
Mute Track 02?

- Continue as above to select the desired tracks that you like to Mute.

### **LOCAL MIDI**

- Press the FUNCTION button and with the data Control Wheel select the Local Midi page

001 : Grand Piano1  
Local MIDI

- Press the ENTER button to confirm and the display will indicate the current Local Midi setting

001 : Grand Piano1  
On : Local MIDI

- Using the Data Control Wheel it is possible to change the Local MIDI On/Off

001 : Grand Piano1  
Off : Local MIDI

### **USB MIDI IN**

- Press the FUNCTION button and with the data Control Wheel select the USB MIDI In page

001 : Grand Piano1  
USB MIDI In

- Press the ENTER button to confirm and the display will indicate the current USB MIDI In setting

001 : Grand Piano1  
Off : USB MIDI In

- Using the Data Control Wheel it is possible to change the USB MIDI In On/Off

001 : Grand Piano1  
On : USB MIDI In

### **USB MIDI OUT**

- Press the FUNCTION button and with the data Control Wheel select the MIDI OUT channel page

001 : Grand Piano1  
MIDI Out

- Press the ENTER button to confirm and the display will indicate the current MIDI OUT channel setting



001 : Grand Piano1  
1 : MIDI Out

- Using the Data Control Wheel it is possible to change the MIDI Out Channel or MIDI Out On/Off setting

001 : Grand Piano1  
2 : MIDI Out

001 : Grand Piano1  
Off : MIDI Out

### **TEACHER DUET**

- Press the FUNCTION button and with the data Control Wheel select the TEACHER DUET page

001 : Grand Piano1  
Teacher Duet

- Press the ENTER button to confirm and the display will indicate the current Teacher Duet On/Off setting

001 : Grand Piano1  
Off : Teacher Duet

- Using the Data Control Wheel it is possible to change the Teacher Duet On/Off setting

001 : Grand Piano1  
On : Teacher Duet

### **SUSTAIN PEDAL – EXPRESSION PEDAL**

- Press the FUNCTION button and with the data Control Wheel select the Half Sustain page

001 : Grand Piano1  
Half Sustain

- Press the ENTER button to confirm and the display will indicate the current Half Sustain On/Off setting

001 : Grand Piano1  
ON : HalfSustain

- Using the Data Control Wheel it is possible to change the Half Sustain On/Off setting

001 : Grand Piano1  
Off : Half Sustain

- Press the FUNCTION button and with the data Control Wheel select the Half Sustain page

001 : Grand Piano1  
Half Sustain

- Using the Data Control Wheel it is possible to change the Half Sustain page to the Expression Pedal.

001 : Grand Piano1  
Expression Pedal

- In this configuration the Sustain Pedal is working as Expression/Volume pedal in the instrument.

## **BLUETOOTH**

- Press the FUNCTION button and with the data Control Wheel select the BLUETOOTH page

001 : Grand Piano1  
Bluetooth

- Press the ENTER button to confirm and the display will indicate the current Bluetooth On/Off setting

001 : Grand Piano1  
On : Bluetooth

- Using the Data Control Wheel it is possible to change the Bluetooth On/Off setting

001 : Grand Piano1  
Off : Bluetooth

## **RESET**

- Press the FUNCTION button and with the data Control Wheel select the RESET page

001 : Grand Piano1  
Reset

- Press the ENTER button to confirm the RESET of the internal volatile memory and to restore the original factory settings and registrations.

001 : Grand Piano1  
Resetmem!

**There is also a different way to Reset your instrument. See in the next page.**

## **AUTO POWER OFF**

- Press the FUNCTION button and with the data Control Wheel select the Auto Power Off page

001 : Grand Piano1  
Auto Power Off

- Press the ENTER button to confirm and the display will indicate the current Auto Power Off setting

001 : Grand Piano1  
30 : Pwr Off (min)

- Using the Data Control Wheel it is possible to change the time in which the instrument will automatically switch Off power is not in use. The value can be changed from a minimum time of 20 minutes to a maximum time of 60 minutes.
- The Auto Power Off feature can be also be switched Off

001 : Grand Piano1  
Off : Pwr Off (min)

## RESET – Direct Reset

Your digital piano is a computer and software based. Sometimes your keyboard will stop functioning properly. As with computers, there can be a “glitch” that can cause a problem. If you have favorites or registrations stored in memory you will lose them when you perform a reset. You will then be able to replace them.

If it should be necessary to completely erase the internal RAM memory, a very simple reset feature is provided.

- 1 - Make sure that the instrument is switched off.
- 2 - Press and hold the (+) YES and (-) NO buttons

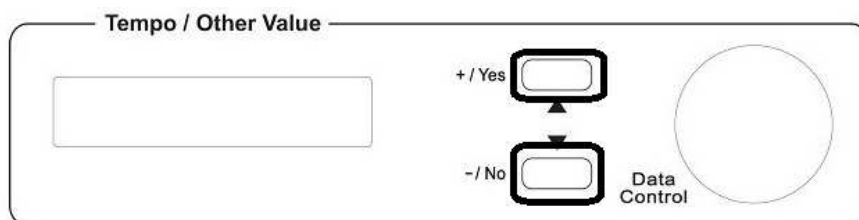

- 3 - Switch on the instrument whilst holding the (+) and (-) buttons down.
- 4 - The display shows Reseting

**Do not reset the instrument if is not necessary. All your information you have programmed will be automatically erased from the internal RAM memory. The factory set programs will be automatically restored.**

## BLUETOOTH Connection Procedure

- 1 Insert the BT1 Receiver in the dedicated socket and the instrument will automatically play a few notes automatically to confirm the BT1 is inserted in its slot.
- 2 When the BT1 receiver is ready, its blue Led will be On and flashing quickly for about 5 seconds. Then it will start flashing at a slower speed after the BT1 will match the Bluetooth device.
- 3 Find now the BT1 on the Bluetooth device (smartphone or tablet) and select it to complete the connection.
- 4 As soon as the connection is completed, the blue Led will stop flashing to indicate the two devices are successfully connected.
- 5 Start playing your audio file from Bluetooth device and have fun.

## CONNECTIONS

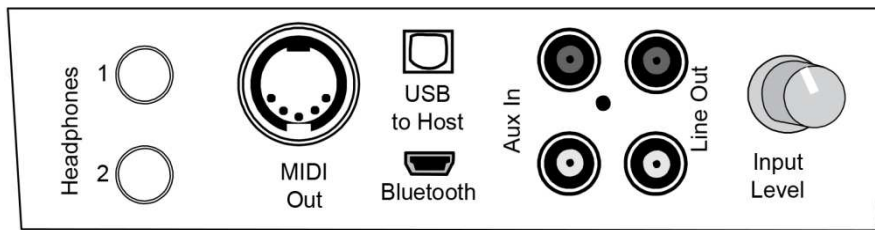

### HEADPHONES

Two sets of Headphones can be plugged in for private practice. The sockets are located at the back of the instrument in left part of the keyboard and allows you to play without disturbing anyone else or being disturbed by outside noise.

### MIDI OUT

The Midi OUT connector transmits Midi data generated by the instrument to other Midi instruments.

### USB TO HOST

It is possible to connect the instrument to a computer using the USB port located in the back panel of the instrument and control the Midi parameters.

### BLUETOOTH

This is the socket where to insert the Bluetooth Receiver unit that allows to connect a Bluetooth transmitting unit (smart phone, tablet, etc) to the instrument audio system.

### AUX IN SOCKETS

There are two inputs (Left and Right) and they are used to send the audio signal of an external instrument to the internal amplifier.

### LINE OUT SOCKETS

There are two outputs (Left and Right) and they are used to send the audio signal to an external amplifier, mixer console or recording equipment. To connect the instrument in Stereo to an external amplification system connect both Left and Right outputs.

### INPUT LEVEL

This is to control the signal level in Aux In input.

## Grand 500/120 Sound List

### PIANOS

Sound Number	PROG CHANGE	BANK	NAME ON DISPLAY	SOUND
1	0	90	Grand Piano1	Grand Piano 1
2	0	0	Grand Piano2	Grand Piano 2
3	0	16	Gr.Piano/Str	Grand Piano + Strings
4	0	24	Octa Piano1	Octave Piano 1
5	0	25	Octa Piano2	Octave Piano 2
6	1	0	Bright Piano	Bright Piano
7	2	0	El.Grand1	Electric Piano 1
8	2	8	El.Grand2	Electric Piano 2
9	3	0	Honky Tonk	Honky Tonky Piano
10	4	0	El.Piano1	Electric Piano 1
11	4	7	Det.El.Pno1	Detuned Electric Piano 1
12	4	8	Mallet El.Pno	Mallet Electric Piano
13	4	16	Soft El.Pno	Soft Electric Piano
14	4	24	Mix El.Pno	Mixed Electric Piano
15	5	0	El.Piano2	Electric Piano 2
16	5	8	Det.El.Pno2	Detuned Electric Piano 2
17	5	9	Galaxy El.Pno	Galaxy Electric Piano
18	5	16	El.Pno/Str	Electric Piano + Strings
19	5	24	El.Pno/Voice	Electric Piano / Voice
20	5	25	Wurly	Wurly Electric Piano
21	6	0	Harpsi1	Harpsichord 1
22	6	8	Harpsi2	Harpsichord 2
23	6	16	Harpsi/Str	Harpsichord / Strings
24	7	0	Clavinet	Clavinet
25	7	8	Funky Clavi	Funky Clavinet
26	8	0	Celesta	Celesta
27	9	0	Glocken	Glockenspiel
28	10	0	MusicBox	Musical Box
29	11	0	Vibes1	Vibraphone 1
30	11	8	Vibes2	Vibraphone 2
31	11	16	Vibes3	Vibraphone 3
32	12	0	Marimba	Marimba
33	12	8	Marimba Rp.	Marimba Repeat
34	13	0	Xylophon	Xylophone
35	14	0	Chimes	Chimes
36	14	8	Churc Bell1	Church Bell 1
37	14	9	Churc Bel2	Church Bell 2
38	14	16	Tubul Bel	Tubular Bell
39	15	0	Dulcimer	Dulcimer

## ORGANS

Sound Number	PROG CHANGE	BANK	NAME ON DISPLAY	SOUND
40	16	0	Drawb Org	Drawbar Organ
41	16	8	Full Fast	Full Organ Fast Rotor
42	16	13	Click Org	Click Organ
43	16	14	Theatre1	Theatre Organ 1
44	16	15	Theatre2	Theatre Organ 2
45	16	16	60' Org	60' Organ
46	16	17	Rock Org1	Rock Organ 1
47	16	18	Cool Org	Cool Organ
48	16	20	Tone Weel	Tone Wheel Organ
49	16	22	Rotor Org	Rotor Organ
50	16	23	Gospl Org	Gospel Organ
51	16	26	Jazz Org1	Jazz Organ 1
52	16	27	Rock Org2	Rock Organ 2
53	17	0	Perc Org1	Percussion Organ 1
54	17	8	Jazz Org2	Jazz Organ 2
55	18	0	Rock Org3	Rock Organ 3
56	19	0	Churc Org1	Church Organ 1
57	19	8	Churc Org2	Church Organ 2
58	19	16	Churc Org3	Church Organ 3
59	19	24	Chruc/Voice	Church Organ / Voice
60	19	33	Flute 168	Organ Flutes 16' + 8'
61	19	34	Flute 164	Organ Flutes 16' + 4'
62	19	35	Flute 162	Organ Flutes 16' + 2'
63	19	36	Theatre	Theatre Organ
64	19	37	Church	Church Organ 4
65	19	38	Chapel	Chapel Organ
66	19	39	Low Org2	Lower Organ 2
67	19	40	Low Org3	Lower Organ 3
68	19	41	Soft Organ	Soft Organ
69	19	42	Tibia1	Tibia 1
70	19	43	Tibia2	Tibia 2
71	19	44	Tibia Vox	Tibia Vox
72	19	45	Theatre3	Theatre 3
73	19	46	Cinema	Cinema Organ
74	19	47	Theatre4	Theatre 4
75	19	48	AmHtge	American Heritage
76	19	50	AmReed	American Reed
77	20	0	Reed Org	Reed Organ
78	21	0	Accordion	Accordion
79	21	8	Master	Master Accordion
80	22	0	Harmonica	harmonica
81	22	8	Blues Harp	Blues Harp
82	23	0	Tango Acd	Tango Accordion

## GUITAR & BASSES

Sound Number	PROG CHANGE	BANK	NAME ON DISPLAY	SOUND
83	24	0	Nylon	Nylon Guitar
84	24	4	Spanish	Spanish Guitar
85	24	8	Brazilian	Brasilian Guitar
86	24	16	Nylon/Str	Nylon Guitar / Strings
87	24	17	Classical	Classical Guitar
88	25	0	Steel Gtr	Steel Guitar
89	25	8	12Str Gtr	12 Strings Guitar
90	25	9	Folk Gtr	Folk Guitar
91	25	10	Unplug Gtr	Unplugged Acoustic Guitar
92	25	16	Mandolin	Italian Mandolin
93	26	0	Jazz Gtr1	Jazz Guitar 1
94	26	1	Jazz Gtr2	Jazz Guitar 2
95	26	2	Jazz Gtr3	Jazz Guitar 3
96	26	4	2Jaz Gtr1	Double Jazz Guitar 1
97	26	5	2Jaz Gtr2	Double Jazz Guitar 2
98	26	6	JGtr +Vib	Jazz Guitar + Vibraphone
99	26	8	Hawaiian1	Hawaiian Guitar 1
100	26	16	Hawaiian2	Hawaiian Guitar 2
101	26	24	Cntry Gtr	Country Guitar
102	27	0	Clean Gt1	Clean Guitar 1
103	27	8	Clean Gt2	Clean Guitar 2
104	27	16	Elect Gtr	Electric Guitar
105	27	24	60' Gtr1	60' Guitar 1
106	27	25	60' Gtr2	60' Guitar 2
107	28	0	Mute Gtr	Mute Guitar
108	28	8	Funk Gtr1	Funk Guitar 1
109	28	16	Funk Gtr2	Funk Guitar 2
110	29	0	Ovrdrive	Overdrive Guitar
111	30	0	Distort	Distortion Guitar
112	30	8	FBakGtr1	Feed Back Guitar 1
113	30	16	Dist.Gtr Vb	Distortion Gyuitar Vibration
114	31	0	Gtr Harm	Guitar Harmonics
115	32	0	Ac.Bass1	Acoustic Bass 1
116	32	1	Ac.Bass2	Acoustic Bass 2
117	32	8	Ac.Bass3	Acoustic Bass 3
118	32	16	Bass/Ride	Acoustic Bass / Ride Cymbal
119	33	0	Fing Bass1	Finger Bass 1
120	33	1	Fing Bass2	Finger Bass 2
121	33	2	Fing Slap	Finger Slap Bass
122	33	3	Fing Bass3	Finger Bass 3
123	33	4	Big Bass1	Big Bass 1
124	33	8	Big Bass2	Big Bass 2
125	33	16	Big BassS	Big Bass Sustain
126	33	24	Org Bass1	Organ Bass 1
127	34	0	Pick Bass	Pick Bass
128	34	8	Bass16+8	Bass 16' + 8'
129	34	16	Bass 8	Bass 8'
130	34	24	Org Bass2	Organ Bass 2
131	34	26	Org Bass3	Organ Bass 3
132	35	0	Fretles1	Fretless Bass 1
133	35	8	Fretles2	Fretless Bass 2
134	36	0	Slap Bass1	Slap Bass 1
135	36	8	Slap Bass2	Slap Bass 2



136	37	0	Slap Bass3	Slap Bass 3
137	37	8	Slap Bass4	Slap Bass 4
138	38	0	Syn Bass1	Synth Bass 1
139	38	8	Syn Bass3	Synth Bass 3
140	38	16	Syn Bass5	Synth Bass 5
141	39	0	Syn Bass2	Synth Bass 2
142	39	8	Syn Bass4	Synth Bass 4

## STRINGS & VOCALS

Sound Number	PROG CHANGE	BANK	NAME ON DISPLAY	SOUND
143	40	0	Violin1	Violin 1
144	40	8	Violin2	Violin 2
145	41	0	Viola	Viola
146	42	0	Cello	Cello
147	43	0	ContraBass	Double Bass
148	44	0	Tremolo Str	Tremolo Strings
149	45	0	Pizzicato	Pizzicato
150	45	8	Pizziocta1	Octave Pizzicato 1
151	45	16	Pizziocta2	Octave Pizzicato 2
152	46	0	Harp	Harp
153	47	0	Timpani	Timpani
154	47	8	Timp. Roll	Timpani Roll
155	48	0	Fast Strings	Fast Strings
156	48	4	Big Fast Str	Big Fast Strings
157	48	16	Dyn Orch	Dynamic Orchestra
158	48	25	Orch/Flute	Orchestra / Flute
159	48	26	Orch/Oboe	Orchestra / Oboe
160	48	27	Orch/Horn1	Orchestra / Horn 1
161	48	28	Orch/Horn2	Orchestra / Horn 2
162	48	29	Orch/WWind	
163	49	0	Slow Strings	Slow Strings
164	49	4	Big Slow Str	Big Slow Attack Strings
165	49	8	Octa Str1	Octave Strings 1
166	49	16	Warm Strings	Warm Strings
167	49	17	Octa Str2	Octave Strings 2
168	49	18	Accmp Str1	Accompaniment Strings 1
169	49	19	Accmp Str2	Accompaniment Strings 2
170	50	0	Syn Strg1	Synth Strings 1
171	51	0	Syn Strg2	Synth Strings 2
172	51	8	Big Pad	Big Pad
173	52	0	ChoirAah	Vocal Choir Aah
174	52	4	Aah/Voice	Vocal Choir Aah / Voice
175	52	8	Big Choir	Big Choir
176	52	16	Voice/Str1	Voice / Strings 1
177	52	17	Voice/Str2	Voice / Strings 2
178	52	18	Str/Voice	Strings / Voice
179	52	24	Voice/Org	Voice / Organ
180	52	25	Voce/Prin8	Voice / Principal 8'
181	53	0	ScatVoice	Scat Voice
182	54	0	Syn Voice	Synth Voice
183	54	8	Pad Voice	Pad Voice
184	54	16	Soft Pad	Soft Pad
185	55	0	Orch Hit	Orchestra Hit

## BRASS & WOODWINDS

Sound Number	PROG CHANGE	BANK	NAME ON DISPLAY	SOUND
186	56	0	Trumpet1	Trumpet 1
187	56	8	Trumpet2	Trumpet 2
188	56	16	Trumpet3	Trumpet 3
189	57	0	Trombon1	Trombone 1
190	57	4	Trombon2	Trombone 2
191	57	8	Melw Tromb	Mellow Trombone
192	57	24	Soft Trom	Soft Trombone
193	58	0	Tuba1	Tuba 1
194	58	8	Tuba2	Tuba 2
195	59	0	MuteTrump	Muted Trumpet
196	60	0	French Hr1	French Horn 1
197	60	4	French Hr 2	French Horn 2
198	60	8	French Hr 3	French Horn 3
199	60	16	Horn Sect	Horn Section
200	60	17	Flugel Hr	Flugel Horn
201	61	0	Brass	Brass
202	61	3	Soft Bras1	Soft Brass 1
203	61	4	Soft Bras2	Soft Brass 2
204	61	8	Soft Bras3	Soft Brass 3
205	61	9	Soft Bras4	Soft Brass 4
206	61	16	Big Bras1	Big Brass Orchestra 1
207	61	24	Big Bras2	Big Brass Orchestra 2
208	61	25	Big Bras3	Big Brass Orchestra 3
209	61	26	Big Bras4	Big Brass Orchestra 4
210	62	0	Syn Bras1	Synth Brass 1
211	62	8	Syn Bras3	Synth Brass 3
212	63	0	Syn Bras2	Synth Brass 2
213	63	8	Syn Bras4	Synth Brass 4
214	64	0	Soprano Sax	Soprano Sax
215	65	0	Alto Sax1	Alto Sax 1
216	65	4	Night Sax	Night Sax
217	65	8	Alto Sax2	Alto Sax 2
218	65	16	Circus Sax	Circus Sax
219	66	0	Tenor Sax	Tenor Sax
220	66	16	Ten SaxVb	Tenor Sax Vibration
221	66	17	Rock Sax	Rock Sax
222	66	24	Sax Sect1	Sax Section 1
223	66	25	Sax Sect2	Sax Section 2
224	66	26	Sax Sect3	Sax Section 3
225	67	0	Bari Sax	Baritone sax
226	68	0	Oboe	Oboe
227	69	0	Engl Horn	English Horn
228	70	0	Bassoon	Bassoon
229	71	0	Clarinet	Clarinet
230	71	8	Trad Clarin	Traditional Clarinet
231	71	16	Mel Clarin	Mellow Clarinet
232	71	25	WoodWind1	Woodwind Section 1
233	71	26	WoodWind2	Woodwind Section 2
234	71	27	WoodWind3	Woodwind Section 3
235	71	28	SymphOrch	Symphonic Orchestra
236	72	0	Piccolo	Piccolo
237	73	0	Flute	Flute
238	73	8	Jazz Flute	Jazz Flute

239	74	0	Recorder	Recorder
240	75	0	Pan Flute	Pan Flute
241	76	0	Bottle	Blow Bottle
242	77	0	Shakhchi	Shakuhachi
243	78	0	Whistle	Whistle
244	79	0	Ocarina	Ocarina

## SYNTH & KEYS

Sound Number	PROG CHANGE	BANK	NAME ON DISPLAY	SOUND
245	80	0	Square1	Square Synth Wave 1
246	80	1	Square2	Square Synth Wave 2
247	80	8	Syn Wave	Synth Wave
248	81	0	Saw 1	Sawtooth Synth Wave 1
249	81	1	Saw 2	Sawtooth Synth Wave 2
250	81	8	Syn Flute	Synth Flute
251	82	0	Calliope	Calliope
252	83	0	Chiff	Chiff
253	84	0	Charang	Charang
254	85	0	Voice	Voice
255	85	8	Voice Sus	Voice Sustain
256	86	0	Fifth	Fifth
257	87	0	Bass Lead1	Synth Bass Lead 1
258	87	8	Bass Lead2	Synth Bass Lead 2
259	88	0	New Age	New Age
260	88	8	Orch Bell	Orchestra Bell
261	88	16	Fantasy	Fantasy
262	89	0	Warm Pad	Warm Pad
263	90	0	Polysynth	Polysynth
264	91	0	Choir	Synth Choir
265	92	0	Bowed	Bowed
266	93	0	Metallic	Metallic
267	94	0	Halo	Halo Pad
268	95	0	Sweep	Sweep Pad
269	96	0	Ice Rain	Ice rain
270	97	0	SoundTrack	Sound Track
271	98	0	Crystal	Crystal
272	99	0	Atmosph1	Atmosphere 1
273	99	8	Atmosph2	Atmosphere 2
274	100	0	Brightns	Bright Synth
275	101	0	Goblins	Goblins
276	101	8	Ghost	Ghost
277	102	0	Echoes	Echoes
278	102	2	EchoPan	Echo Pan
279	103	0	SciFi	SciFi

## ACCORDIONS

Sound Number	PROG CHANGE	BANK	NAME ON DISPLAY	SOUND
280	0	32	Bassoon	Bassoon
281	1	32	Cassotto	Cassotto
282	2	32	D.Basson	Double Basson
283	3	32	16+16+8	16'+16'+8' Accordion
284	4	32	Bandon1	Bandoneon 1
285	5	32	Bandon2	Bandoneon 2
286	6	32	TubaFisa	Tuba Accordion
287	7	32	Accord	Accordion
288	8	32	Horn	Horn Accordion
289	9	32	Organ	Organ Accordion
290	10	32	Harmon	Harmon
291	11	32	Master 1	Master 1
292	12	32	Master 2	Master 2
293	13	32	Master 3	Master 3
294	14	32	Master 4	Master 4
295	15	32	Master 5	Master 5
296	16	32	Master 6	Master 6
297	17	32	Musette	Musette
398	18	32	French	French Accordion
399	19	32	Italian	Italian Accordion
300	20	32	Brillant	Brillant Accordion
301	21	32	Violino	Violino Accordion
302	22	32	Celeste	Celeste Accordion
303	23	32	Tremolo	Tremolo Accordion
304	24	32	AmerTrem	American Tremolo Accordion
305	25	32	T.Accord	Tango Accordion
306	26	32	Mus+Picc	Musette + Piccolo Accordion
307	27	32	Oboe 1	Oboe Accordion 1
308	28	32	Oboe 2	Oboe Accordion 2
309	29	32	Clarinet	Clarinet Accordion
310	30	32	Flute	Flute Accordion
311	31	32	Piccolo	Piccolo Accordion
312	32	32	Diatonic	Diatonic Accordion
313	33	32	DiatBass	Diatonic Accordion Bass
314	34	32	DiatChrd	Diatonic Accordion Chord
315	35	32	AccBass1	Accordion Bass 1
316	36	32	AccBass2	Accordion Bass 2
317	37	32	AccChrd1	Accordion Chord 1
318	38	32	AccChrd2	Accordion Chord 2
319	39	32	AccChrd3	Accordion Chord 3

## WORLD INSTRUMENTS

Sound Number	PROG CHANGE	BANK	NAME ON DISPLAY	SOUND
320	104	0	Sitar	Sitar
321	105	0	Banjo	Banjo
322	105	8	Banjo Repeat	Banjo Repeat
323	106	0	Shamisen	Shamisen
324	107	0	Koto 1	Koto 1
325	107	8	Koto 2	Koto 2
326	108	0	Kalimba	Kalimba
327	109	0	Bagpipe	Bagpipe
328	109	8	Uilleann Pipe	Uilleann Pipe
329	110	0	Fiddle	Fiddle
330	111	0	Shanai	Shanai

## DRUM & PERCUSSION

Sound Number	PROG CHANGE	BANK	NAME ON DISPLAY	SOUND
331	112	0	TnkIBell	Tinkle Bell
332	113	0	Agogo	Agogo
333	114	0	Steel Drum	Steel Drum
334	115	0	WoodBlok	Wood Block
335	115	8	Castanet	Spanish Castanet
336	116	0	Taiko Drum	Taiko Drum
337	116	8	ConBasDr	Concert Bass Drum
338	117	0	Mel Tom1	Melodic Tom 1
339	117	8	Mel Tom2	Melodic Tom 2
340	118	0	Syn Drum1	Synth Drum 1
341	118	8	Syn Drum2	Synth Drum 2
342	118	9	Syn Drum3	Synth Drum 3
343	119	0	Rev Cymbal	Reverse Cymbal
344	120	0	Fret Noise	Guitar Fret Noise
345	121	0	Breath Noise	Breath Noise
346	122	0	Seashore	Seashore
347	123	3	Birds	Birds
348	124	0	Telphon1	Telephone 1
349	125	0	Helicopter	Helicopter
350	126	0	Applause	Applause
351	127	0	Gun Shot	Gun Shot
352	0		Standard	Standard Drum Kit
353	8		Room	Room Drum Kit
354	16		Power	Power Drum Kit
355	24		Electric	Electric Drum Kit
356	25		Dance	Dance Drum Kit
357	32		Jazz	Jazz Drum Kit
358	40		Brush	Brush Drum Kit
359	48		Classic	Classic Drum Kit
360	63		Acoustic	Acoustic Drum Kit
361	64		Modern	Modern Drum Kit
362	56		Effects	Many different Sound Effects

## Grand 500/120 Style List

### POP ROCK

Number	NAME ON DISPLAY	STYLE
1	8Beat	8 Beat
2	8Beat 1	8 Beat 1
3	8Beat 2	8 Beat 2
4	8Beat 3	8 Beat 3
5	8Beat 4	8 Beat 4
6	8Beat 5	8 Beat 5
7	8Beat 6	8 Beat 6
8	8BtModrn	8 Beat Modern
9	50sGuitar	50's Guitar
10	60'8Beat	60's 8 Beat
11	60'organ	60's Organ
12	60'pop	60's Pop
13	Detro Pop	Detroit pop
14	Mod3/4	Modern ¾
15	Folk Pop	Folk Pop
16	Guitar Pop	Guitar Pop
17	16Beat	16 Beat 1
18	16Beat 2	16 Beat 2
19	16Beat 3	16 Beat 3
20	Mersey Beat	Mersey Beat
21	Beach Boy	Beach Boy
22	PopShufl	Pop Shuffle
23	PopOrgan	Pop Organ
24	KoolShuf	Kool Shuffle
25	Pick Up	Pick Up Style
26	Fusion	Fusion
27	80's Rock	80's Roc
28	Rock	Rock 1
29	Rock 2	Rock 2
30	Rock 3	Rock 3
31	RockRoll	Rock & Roll
32	50R'N'RL	50's Rock & Roll
33	50s'Rock	50's Rock
34	Slow 6/8	Slow 6/8

### COUNTRY

Number	NAME ON DISPLAY	STYLE
35	Country	Country 1
36	Country 2	Country 2
37	Country 3	Country 3
38	Country 4	Country 4
39	Chetkins	Chetkins Style

40	Cntry Sw	Country Swing 1
41	Cntry Sw 2	Country Swing 2
42	Ez Cntry	Easy Country
43	LatCntry	Latin Country
44	SlowCtry	Slow Country
45	Ctry Pop	Country Pop
46	Ctry 2/4	Country 2/4
47	Ctry 3/4	Country 3/4
48	CtryWltz	Country Waltz
49	CtryBalld	Country Ballad
50	8BtCtry	8 Beat Country 1
51	8BtCtry 2	8 Beat Country 2
52	Ctry 2Bt	Country 2 Beat 1
53	Ctry 2Bt 2	Country 2 Beat 2
54	CtryBeat	Country Beat
55	CtryRock	Country Rock 1
56	CtryRok2	Country Rock 2
57	Ctry Dance	Country Dance
58	ModParty	Modern Party
59	Bluegras	Bluegrass 1
60	Bluegras 2	Bluegrass 2
61	EasyShufl	Easy Shuffle
62	50'Shufl	50's Shuffle
63	70'Shufl	70's Shuffle
64	Sixtie	Sixties Country
65	Western	Western

#### STANDARD & OLDIES

Number	NAME ON DISPLAY	STYLE
66	Basie	Basie Style
67	DanceBnd	Dance Band
68	SlowBand	Slow Band
69	MuteBand	Muted Band
70	Swngband	Swing Band
71	ShowBand	Show Band
72	ShowTime	Show Time
73	Showball	Show Ballad
74	Big Band	Big Band
75	B_B_Ball	Big Band Ballad
76	B_B_Fast	Big Band Fast
77	30s'Swin	30's Swing
78	BBndSwng	Big Band Swing
79	Broadway	Broadway
80	Ez_Jazz	Easy Jazz 1
81	EasyJz 2	Easy Jazz 2
82	Jazz Ballad	Jazz Ballad
83	Jazz Club	Jazz Club
84	Swing	Swing
85	SimpleSwng	Simple Swing
86	SlowSwng	Slow Swing
87	Fastswng	Fast Swing 1

88	Fstswng2	Fast Swing 2
89	Swingy Reg	Swingy Reggae
90	20'sSwng	20's Swing
91	Bounce	Bounce
92	Dixie	Dixieland 1
93	Dixie2	Dixieland 2
94	Dixie3	Dixieland 3
95	DixieBar	Dixie
96	Trad Band	Traditional Band
97	Theatre	Theatre
98	Theat 2/4	Theatre 2/4
99	Theat 6/8	Theatre 6/8
100	FoxTrot	Fox Trot 1
101	FoxTrot 2	Fox Trot 2
102	FoxTrot 3	Fox Trot 3
103	FoxTrot 4	Fox Trot 4
104	Slowfox	Slow Fox
105	EuroFox	Euro Fox

## LATIN 1

Number	NAME ON DISPLAY	STYLE
106	Bossa	Bossa Nova 1
107	Bossa 2	Bossa Nova 2
108	Bossa 3	Bossa Nova 3
109	Bossa 4	Bossa Nova 4
110	JzBossa	Bossa Nova 5
111	SlwBossa	Slow Bossa Nova
112	BensNova	Benson Bossa
113	ModBossa	Modern Bossa
114	ModLatin	Modern Latin
115	LatJazz	Latin Jazz 1
116	LatJazz2	Latin Jazz 2
117	LatnRock	Latin Rock
118	Samba	Samba 1
119	Samba 2	Samba 2
120	Samba 3	Samba 3
121	Sambaorg	Samba Organ
122	SambaPop	Samba Pop
123	Dsc Samb	Disco Samba 1
124	DscSamb2	Disco Samba 2
125	BB Samba	Big Band Samba
126	Salsa	Salsa
127	Bachata	Bachata
128	Guaracha	Guaracha
129	Macarena	Macarena
130	Reggaton	Reggaton
131	Bajon	Bajon
132	Limbo	Limbo



**JAZZ & BLUES**

Number	NAME ON DISPLAY	STYLE
133	JazzRock	Jazz Rock 1
134	JazzRok2	Jazz Rock 2
135	Boogie	Boogie Woogie 1
136	Boogie 2	Boogie Voogie 2
137	Jive	Jive 1
138	Jive 2	Jive 2
139	PnBoogie	Piano Boogie
140	Shuffle	Shuffle
141	ShuffPno	Shuffle Piano
142	Twist	Twist
143	Ragtime	Rag Time 1
144	Ragtime2	Rag Time 2
145	Stride	Stride
146	Stridpia	Stride Piano 1
147	Stridpia 2	Stride Piano 2
148	CoolJazz	Cool Jazz
149	Honky T.	Honky Tonky
150	Bluesy	Bluesy
151	Blues	Blues 1
152	Blues 2	Blues 2
153	68Blues	6/8 Blues 1
154	68Blues 2	6/8 Blues 2
155	R&Blues	Rhythm & Blues 1
156	R&Blues 2	Rhythm & Blues 2
157	BluesMan	BluesMan
158	Gospel	Gospel 1
159	Gospel 2	Gospel 2
160	Gospel 3	Gospel 3
161	Gospel 4	Gospel 4
162	GospShuf	Gospel Shuffle 1
163	GospShuf 2	Gospel Shuffle 2
164	Gosp 3/4	Gospel 3/4
165	6/8 Soul	6/8 Soul
166	ModernJz	Modern Jazz
167	JazzMan	JazzMan
168	VoxSwing	Vox Swing
169	Singsong	Sing Song
170	Barndanc	Barn Dance

**BALLAD**

Number	NAME ON DISPLAY	STYLE
171	New Age	New Age
172	Ballad	Ballad 1
173	Ballad 2	Ballad 2
174	SoftBall	Soft Ballad
175	NewBall	New Ballad
176	50's Bld	50's Ballad
177	PopBall	Pop Ballad

178	Nice&Esy	Nice & Easy
179	LoveSong	Love Song 1
180	LoveSong 2	Love Song 2
181	PnoBalad	Piano Ballad 1
182	PnoBalad 2	Piano Ballad 2
183	PnoBalad 3	Piano Ballad 3
184	EpicBalad	Epic Ballad
185	LoveBalad	Love Ballad
196	68Ballad	6/8 Ballad
187	Aria	Aria
188	SlwBalla	Slow Ballad
189	Slowrock	Slow Rock 1
190	Slowrok2	Slow Rock 2
191	SlowRok3	Slow Rock 3
192	SlowRok4	Slow Rock 4
193	Lulbywal	Lullaby
194	LoungePn	Lounge Piano
195	PianoBar	Piano Bar

## BALLROOM

Number	NAME ON DISPLAY	STYLE
196	Tango	Tango 1
197	Tango 2	Tango 2
198	Tango 3	Tango 3
199	EleganTg	Elegant Tango
200	Habanera	Habanera 1
201	Habanera 2	Habanera 2
202	PsoDoble	Paso Doble 1
203	PsoDobl2	Paso Doble 2
204	SoftSho	Soft Shoe
205	Charlest	Charleston
206	Tip Tap	Tip Tap
207	QuickStp	Quick Step 1
208	QuikStp2	Quick Step 2
209	Quikstp3	Quick Step 3
210	QuikStp4	Quick Step 4
211	Organ_Qs	Organ Quick Step
212	EasyQuik	Easy Quick Step
213	Polka	Polka 1
214	Polka 2	Polka 2
215	It Polka	Italian Polka
216	Poppolka	Pop Polka 1
217	Poppolka2	Pop Polka 2
218	PartyPol	Party Polka 1
219	PartyPol2	Party Polka 2
220	2/4 Polka	2/4 Polka
221	6/8 Polka	6/8 Polka
222	Waltz	Waltz
223	StdWaltz	Standard Waltz
224	OrchWalz	Orchestra Waltz

225	SIWaltz	Slow Waltz 1
226	SIWaltz2	Slow Waltz 2
227	SIWaltz3	Slow Waltz 3
228	EleganWz	Elegant Waltz
229	OrgWaltz	Organ Waltz
230	Jz Waltz	Jazz Waltz 1
231	Jz Waltz 2	Jazz Waltz 2
232	ModWaltz	Modern Waltz
233	Musette	Musette Waltz
234	Oompah	Oompah Waltz
235	TradWtz	Traditional Waltz

## DANCE

Number	NAME ON DISPLAY	STYLE
236	SwingHse	Swing House 1
237	SwingHse 2	Swing House 2
238	House	House
239	CumbiaOr	Cumbia Organ
240	Club Dance	Club Dance
241	CbLatin	Club Latin
242	Dance Pop	Dance Pop
243	UKPop	UK Pop
244	British	British Style
245	HHGroove	HH Groove
246	Hip Hop	Hip Hop 1
247	Hip Hop 2	Hip Hop 2
248	Techno	Techno 1
249	Techno 2	Techno 2
250	Kylie Pop	Kylie Pop
251	Chillout	Chillout
252	Motsound	Motown Sound
253	Acid Jazz	Acid Jazz
254	Garage	Garage
255	Rap	Rap 1
256	Rap 2	Rap 2
257	Funk	Funk
258	Disco	Disco 1
259	Disco 2	Disco 2
260	Disco 3	Disco 3
261	Disco 4	Disco 4
262	60's Dsc	60's Disco
263	70's Dsc	70's Disco 1
264	70'sDsc2	70's Disco 2
265	70'sDsc3	70's Disco 3
266	70'sDsc4	70's Disco 4
267	70'sDsc5	70's Disco 5
268	Village Disco	Village Disco
269	Disco Party	Disco Party
270	Philly	Philly Sound
271	Soul	Soul

272	SwinRock	Swing Rock
273	Fisa Dance	Fisa Accordion Dance
274	PartyDance	Party Dance
275	DanceLove	Dance Love
276	PartyBald	Party Ballad
277	HulyGuly	Hully Gully 1
278	HulyGuly2	Hully Gully 2

## LATIN 2

Number	NAME ON DISPLAY	STYLE
279	Rhumba	Rhumba 1
280	Rhumba 2	Rhumba 2
281	Rhumba 3	Rhumba 3
282	Rhumba 4	Rhumba 4
283	Rhumba 5	Rhumbe 5
284	Beguine	Beguine 1
285	Beguine2	Beguine 2
286	Beguine3	Beguine 3
287	Mambo	Mambo 1
288	Mambo2	Mambo 2
289	DscMambo	Disco Mambo
290	ChaCha	Cha Cha 1
291	ChaCha 2	Cha Cha 2
292	ChaCha 3	Cha Cha 3
293	Bolero Orch.	Bolero Orchestra
294	Bolero 2	Bolero 1
295	Bolero 3	Bolero 3
296	Meneito	Meneito 1
297	Meneito 2	Meneito 2
298	Talisman	Talisman
299	Merengue	Merengue 1
300	Mereng 2	Merengue 2
301	Mereng 3	Merengue 3
302	Bamba	Bamba
303	Gipsy	Gipsy
304	Reggae	Reggae 1
305	Reggae 2	Reggae 2
306	UbReggae	UB Reggae
307	Lambada	Lambada

## WORLD

Number	NAME ON DISPLAY	STYLE
308	Flamenco	Famenco
309	Corrida	Corrida
310	Argentin	Argentin 1
311	Argentin 2	Argentin 2
312	March 2/4	March 2/4

313	March	March
314	March 6/8	March 6/8 1
315	March68	March 6/8 2
316	Epic March	Epic March
317	Tarantel	Tarantella 1
318	Tarantel2	Tarantella 2
319	Tarantel3	Tarantella 3
320	Saltarel	Saltarello
321	Polka Ita	Polta Italiana
322	OberPolk	Ober Polka
323	Quadrigl	Quadriglia
324	Reel 2/4	Reel 2/4
325	Reel 6/8	Reel 6/8
326	IrishJig	Irish Jiga
327	Hawaiian	Hawaiian
328	Sirtos	Sirtos
329	Sirtaki	Sirtaki
330	Mariachi	Mariachi
331	Baroque	Baroque 1
332	Baroque2	Baroque 2
333	Calipso	Calipso
334	Arabic 1	Arabic 1
335	Arabic 2	Arabic 2
336	Arabic 3	Arabic 3
337	Zebekiko	Zebekiko
338	Eastern	Eastern
339	Fr Waltz	French Waltz
340	It Waltz	Italian Waltz
341	Mazurka	Mazurka 1
342	Mazurka2	Mazurka 2
343	Mazurka3	Mazurka 3
344	Mazurka4	Mazurka 4
345	Mazurkz5	Mazurka 5
346	Celtic 3/4	Celtic ¾
347	TirolWtz	Tirol Waltz
348	Vienna	Vienna Waltz
349	Viennese	Viennese 1
350	Viennese 2	Viennese 2





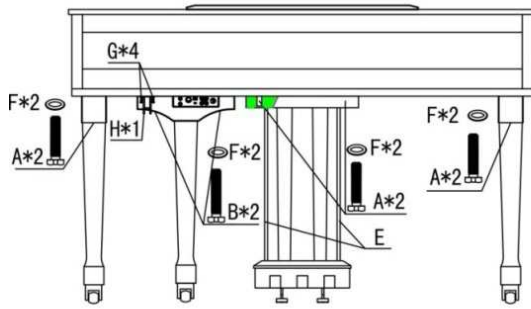

## MIDI IMPLEMENTATION CHART

Function	Transmitted	Recognized	Remark
Basic Channel	1 CH	1-16 CH	
Channel changed	1-16 CH	1-16 CH	
Default Mode	3	3	
Note Number 9-120 0-127			
Velocity: Note On	•	•	
Velocity: Note Off	X	•	
Pitch Bender	•	•	
Control Change: 0	•	X	Variation page
1	X	X	Modulation
5	X	X	Portamento value
7, 10	•	•	Volume, Pan
11	X	•	Expression
64, 66, 67	•	•	Sustain. Sostenuto, Soft Pedal
65	X	X	Portamento yes/no
80, 81	•	•	Reverb, Chorus program
91	•	•	Reverb, Chorus send level
98, 99	X	X	NRPNL, NRPHH
100, 101	X	X	RPNL, RPNH
121	•	•	Reset all controllers
123	•	•	All notes off
Program Change	0-127	0-127	
System Exclusive	X	X	
Sys. Common: Song	X	X	
Select	X	X	
Sys. Common: Song Position	X	X	
System: Clock	X	X	
Real Time: Commands	X	X	

# Grand 500 Digital Piano

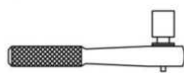
Assembly Drawing





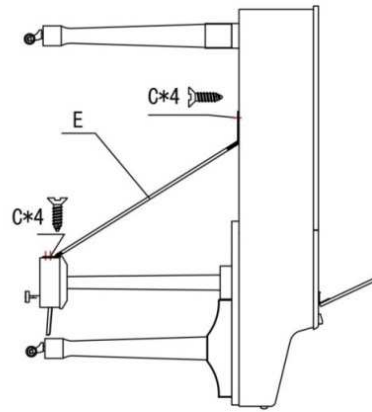
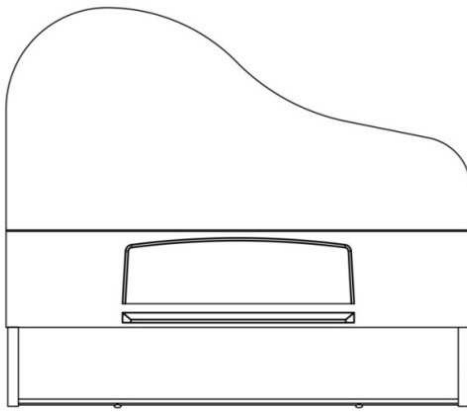



- A:  X6 M12X50
- B:  X2 M12X70
- C:  X8 ST3. 9X12
- D: 
- E:  X2
- F:  X8 D=13
- G:  X4 M4X12
- H:  X1

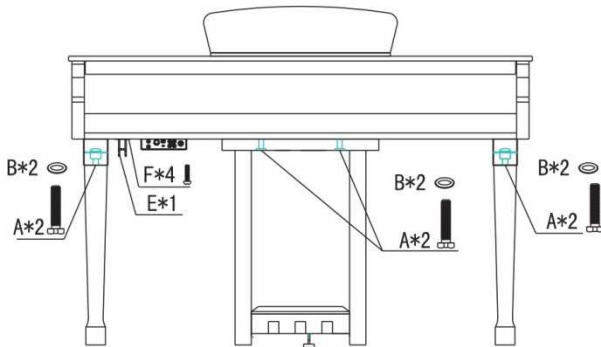

# Grand 120 Digital Piano

Assembly Drawing

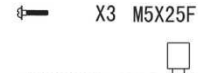

- A:  X6 M12X50
- B:  X6 D=12
- C:  X3 M5X25F
- D: 
- E:  X1
- F:  X4 M4X12

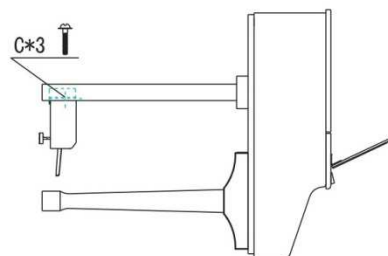
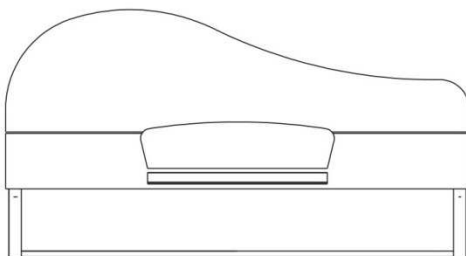

**ORLA**